



Freestanding Coils

PRODUCT DATA & SPECIFICATIONS

Bulletin T70-FSC-PDS-1
Part # 1106612

- Water / Glycol Heating & Cooling
- Direct Expansion
- Heat Reclaim / Condensers

	PRODUCT SUPPORT	<i>scan:</i>
	web: t-rp.com/coils	
	email: ahu@t-rp.com	
	call: 1-844-893-3222 x521	



CONTENTS

	Page
Nomenclature.....	2
Specifications	2 - 3
Features and Options.....	4
Coil Selection.....	5
Dimensional Data.....	6 - 8
Circuiting.....	9
Coil Checklist.....	10
Product Support Resources.....	BACK

NOMENCLATURE

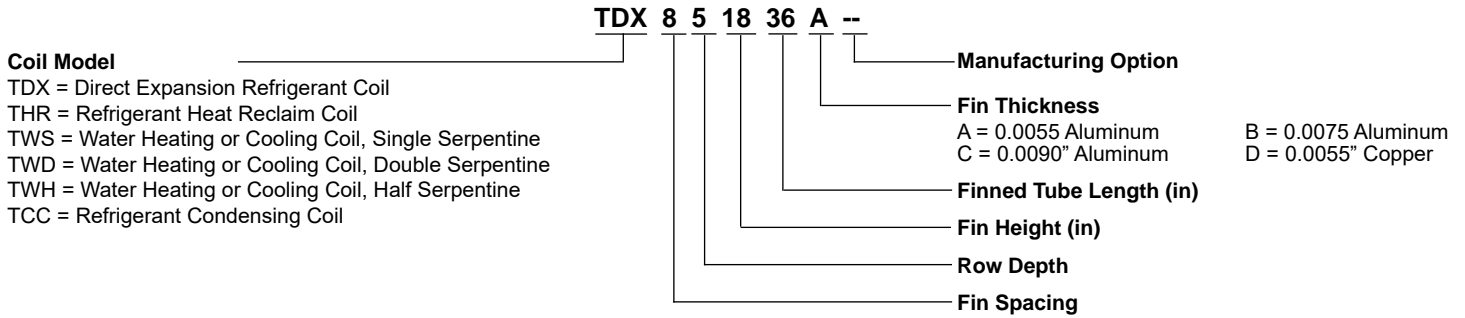

SPECIFICATIONS

Tubes

Coils are fabricated with seamless copper tubes with tube centres staggered in direction of air flow. Tubes are mechanically expanded into fully collared aluminum fins. No water is used in expansion process. No optional tubing is available.

Water heating coils are 4 rows deep maximum. Steam heating coils are 2 rows deep maximum.

Coil Type	Tube Pattern	Tube Wall Thickness
Direct Expansion (TDX)	5/8"x1.50"x1.299"	0.018"
Condenser (TCC) *	1/2"x1.50"x1.299"	0.016"
Heat Reclaim (THR) *	1/2"x1.50"x1.299"	0.016"
Water Cooling/Heating (TW)	5/8"x1.50"x1.299"	0.025"

* 5/8 tubing optional.

Fin

Fins have a ripple pattern for increased heat transfer and to provide additional stiffness to the fin. Fully drawn collars provide an efficient thermal bond with the tubes and allow accurate fin spacing.

All coil models have standard 0.0055" thick fin material as standard with 0.0075" or 0.0090" thick fin material available as an option. See optional fin and tube price page for list adder.

Fin Thickness	Fin Spacing	Fin Material
0.0055"	8 to 14 FPI	Aluminum & Copper
0.0075"	6 to 12 FPI	Aluminum
0.0090"	4.5 to 8 FPI	Aluminum

Casings

Coil casings are fabricated from G90 galvanized sheet metal. End plates are 14 to 16 gauge. Top and bottom plates are 14 to 18 gauge.

Casings are provided with 1 1/2" wide flanges with 3/8" diameter mounting holes on 3" centres from the middle of the coil casing. Top and bottom plates have a double break flange to form a channel section for added rigidity and to allow "stacking" of coils. End plates are built with formed, collared tube holes to provide additional tube support. Coils over 60" finned tube length are provided with intermediate support channels across their width for additional rigidity.

Casings may be provided in materials other than galvanized steel and with dimensions other than standard dimensions. Consult options price notes for additional information.

Headers and Distributors

Headers are made from copper tubing provided with brazed copper end discs.

Water heating and cooling coils are provided with 1/8" F.P.T. drain and vent connections at the bottom of the supply header and the top of the return header. Supply and return connections are MPT copper fittings. It can also be provided with optional intermediate drain headers interconnected with return bends for improved coil draining.

Direct expansion coils, condensing coils and refrigerant heat reclaim coils are supplied with mitered suction and supply headers suitable for brazing to copper refrigerant line. Direct expansion coils are provided with 1/4" diameter equalizer line at the suction header.

Refrigerant distributors are factory installed. Distributors may be supplied with auxiliary side connections for hot gas defrost or capacity control as an option.

SPECIFICATIONS (cont'd)

Pressure Testing And Dehydration

TDX direct expansion coils are pressure tested at 300 PSIG under water. TCC condenser coils, THR reheat coils and TW water cooling/heating coils are tested at 450 PSIG under water to ensure leak free coils. All coils are dried thoroughly after testing.

Crating

Coils are packaged for shipment in open crating with Aspenite sheeting protecting fin surfaces on each side of the coil.

Coil Coatings

Trenton Refrigeration offers various optional coil coatings as service to our customers. As equipment can be exposed to a variety of atmospheric conditions that are beyond Trenton Refrigeration's control, customers need to decide which coating best suits their application needs. All coil coatings are sold and applied by third party suppliers and while these products can extend the life and integrity of the equipment, Trenton Refrigeration cannot recommend, endorse or warrant any of these products. For more information on coil coatings, visit our website at www.t-rp.com/coilcoatings or contact your local Trenton Refrigeration representative for assistance.

Primary Surface

1/2" or 5/8" round seamless copper tubes are mechanically expanded, offering positive, permanent, metal to metal contact for efficient heat transfer.

Secondary Surface

Rippled, plate type aluminum fins create the maximum air turbulence necessary to obtain efficient transfer of heat. Wide, full, fin collars, smoothly drawn completely cover the tubes increasing the contact area.

Operating Conditions

Complete core rated at 200 PSIG working pressure.

Circuiting

Each Direct Expansion Coil is circuited for low pressure drop with sufficient vapor velocity to insure maximum heat transfer. All circuits are of equal length and all carry equal loads.

Casing

Die formed heavy gauge casings are formed from Continuous Galvanized Steel. Three eighths inch bolt holes on 3" centers are provided in mounting frames.

Tests

Complete Coil assembly is tested at 315 PSIG air under warm water. Dehydrated by heating and circulating hot dry air (-40°F, dew-point) throughout the coil and then sealed.

Special Refrigerants

For use with special refrigerants consult the factory.

Special Purpose Coils

Protective coatings, special materials, and fin spacings to meet your individual needs are available for industrial and process applications

Brazing

All Core joints are made with copper brazing alloys.

Return Bends

1/2" or 5/8" O.D. round seamless copper tubing.

Header End Caps

Heavy gauge copper.

Liquid Distributors

Pressure type brass distributors with accurately spaced drilled outlets are furnished and mounted on each coil to insure equal distribution of refrigerant to all circuits. Expansion valve may be field installed and coil can be mounted in any position.

Connections

Male Sweat type. Liquid connections are brass and suction connections are copper.

FEATURES

Staggered Tubes

Experience and field tests prove conclusively that staggered tubes produce at least 5% higher capacity than parallel tubes.

Rippled Fins

Experience and field tests prove conclusively that fins which ripple through fin depth produce a minimum of 5% higher performance than flat plate fins.

Higher Heat Transfer Rate

A combination of staggered tubes and modified rippled fins, produces the necessary turbulence to interrupt the insulating boundary layer film, while retaining the intimate and prolonged contact between air and the heat exchanger surface.

Non Ferrous Headers

Heavy wall seamless copper headers and copper tubes eliminate leaks which could occur from unequal expansion rates of dissimilar materials as well as from the possibility of galvanic corrosion. Natural resistance of copper to corrosion means longer coil life.

Flow Circuiting

All coils are counterflow circuited and equipped with pressure type distributors to insure equal distribution of refrigerant to each circuit. Sufficient circuits are provided to insure equal distribution of refrigerant to each circuit. Circuiting for face-control and row-control is also available.

Full Fin Collars

Wide, smooth die-formed fin collars provide accurate fin spacing and completely cover the coil tube for maximum contact area and highest heat transfer.

Full Face Height (Without Air By-Pass) Positive Permanent Tube Fin Bond

Mechanical pressure expansion of the tube into the fin provides a positive and permanent metal to metal contact for durability and peak performance.

Unmatched Variety Of Standard Coils

Provides practically unlimited flexibility in selection of coils to more accurately meet load requirements.

OPTIONS

AVAILABLE IN FOUR STANDARD FIN SPACING

70 Fin Series

Designed and used for applications requiring high latent loads and for installations requiring low air pressure drop. With the 70 Fin Series Coil, it is possible to more accurately match sensible and total loads, particularly when the water temperature is low and the entering wet bulb air temperature is high.

80 Fin Series

This fin series and the 100 Fin Series surface are widely used for regular commercial applications because the S/T ratios achieved with these surfaces meet the normal S/T ratio requirements. When only the 80 Fin Series Coil surface was available, frequently more rows of coil were required to meet either a total or sensible load than is now required with 100 and 120 Fin Series Coils. When extra rows are furnished to meet either a sensible or total requirement, the excessive capacity furnished can result in something less than ideal conditions in the conditioned space.

100 Fin Series

For special industrial applications that require higher than normal sensible cooling loads. Experience has shown this is an excellent heat transfer surface, not only for high sensible requirements, but also for average S/T ratio jobs, when space will not permit larger face areas and/or more rows to be installed and capacity requirements exceed the capabilities of 80 Fin Series Coils. The increase in air friction that results by changing from an 80 Fin Series to a 100 Fin Series with shallow depth coils is usually less than the increase in air friction if one additional row of 80 Fin Series Coil is utilized.

120 Fin Series

A maximum capacity surface with reasonable air pressure drop and is particularly suitable for use in commercial and industrial installations requiring higher than average sensible total ratios. The 120 Fin Series heat transfer surface offers the maximum BTU capacity per dollar invested for applications where this surface is suitable. The 120 Fin Series provides the maximum amount of total external surface per sq. ft. of face area per row deep that is practical without encountering excessive air pressure drops.

COIL SELECTION - COIL SIZES

COIL SIZES - NOMINAL FACE AREA IN SQ. FT.

"W" INCHES	NOMINAL TUBE LENGTH - NTL - (INCHES)																						
	12	15	18	21	24	27	30	33	36	39	42	45	48	51	54	57	60	63	66	69	72	75	78
9	0.75	0.94	1.12	1.31	1.50	1.69	1.87	2.06	2.25	2.44	2.62	2.81	3.0	3.2	3.4	3.6	3.7	3.9	4.1	4.3	4.5		
12	1.00	1.25	1.50	1.75	2.00	2.25	2.50	2.75	3.00	3.25	3.50	3.75	4.0	4.3	4.5	4.8	5.0	5.3	5.5	5.8	6.0	6.3	6.5
15		1.56	1.87	2.19	2.50	2.81	3.12	3.44	3.75	4.06	4.37	4.68	5.0	5.3	5.6	5.9	6.2	6.6	6.9	7.2	7.5	7.8	8.1
18			2.25	2.62	3.00	3.37	3.75	4.12	4.50	4.87	5.25	5.62	6.0	6.4	6.7	7.1	7.5	7.9	8.2	8.6	9.0	9.4	9.7
21				3.06	3.50	3.94	4.37	4.82	5.25	5.69	6.12	6.56	7.0	7.4	7.9	8.3	8.7	9.2	9.6	10.1	10.5	10.9	11.4
24					4.00	4.50	5.00	5.50	6.00	6.50	7.00	7.50	8.0	8.5	9.0	9.5	10.0	10.5	11.0	11.5	12.0	12.5	13.0
27						5.06	5.62	6.19	6.75	7.32	7.87	8.44	9.0	9.6	10.1	10.7	11.2	11.8	12.4	12.9	13.5	14.1	14.6
30							6.25	6.88	7.50	8.12	8.75	9.37	10.0	10.6	11.2	11.9	12.5	13.1	13.7	14.4	15.0	15.6	16.2
33								7.56	8.25	8.94	9.62	10.30	11.0	11.7	12.4	13.1	13.7	14.4	15.1	15.8	16.5	17.2	17.9
36									9.00	9.75	10.50	11.20	12.0	12.7	13.5	14.2	15.0	15.7	16.5	17.2	18.0	18.7	19.5

"W" INCHES	NOMINAL TUBE LENGTH - NTL - (INCHES)																					
	81	84	87	90	93	96	99	102	105	108	111	114	117	120	123	126	129	132	135	138	141	144
12	6.8	7.0	7.3	7.5	7.8	8.0	8.3	8.5	8.8	9.0	9.3	9.5	9.8	10.0								
15	8.4	8.7	9.1	9.4	9.7	10.0	10.3	10.6	10.9	11.2	11.6	11.9	12.2	12.5								
18	10.1	10.5	10.9	11.2	11.6	12.0	12.4	12.7	13.1	13.5	13.9	14.2	14.6	15.0	15.4	15.8						
21	11.8	12.2	12.7	13.1	13.6	14.0	14.4	14.9	15.3	15.7	16.2	16.6	17.1	17.5	17.9	18.4	18.8	19.3				
24	13.5	14.0	14.5	15.0	15.5	16.0	16.5	17.0	17.5	18.0	18.5	19.0	19.5	20.0	20.5	21.0	21.5	22.0	22.5	23.0	23.5	24.0
27	15.2	15.7	16.3	16.9	17.4	18.0	18.6	19.1	19.7	20.2	20.8	21.4	21.9	22.5	23.1	23.6	24.2	24.8	25.3	25.9	26.4	27.0
30	16.9	17.5	18.1	18.7	19.3	20.0	20.6	21.2	21.9	22.5	23.1	23.7	24.4	25.0	25.6	26.2	26.9	27.5	28.1	28.8	29.4	30.0
33	18.6	19.2	19.7	20.6	21.3	22.0	22.7	23.4	24.0	24.7	25.4	26.1	26.8	27.5	28.2	28.9	29.6	30.2	30.9	31.6	32.3	33.0
36	20.2	21.0	21.8	22.5	23.2	24.0	24.7	25.5	26.2	27.0	27.7	28.5	29.2	30.0	30.7	31.5	32.2	33.0	33.7	34.5	35.2	36.0

Type TDX coils over 120" N.T.L. are considered special.
Consult factory for coils other than sizes shown above

DIMENSIONS - TDX COILS

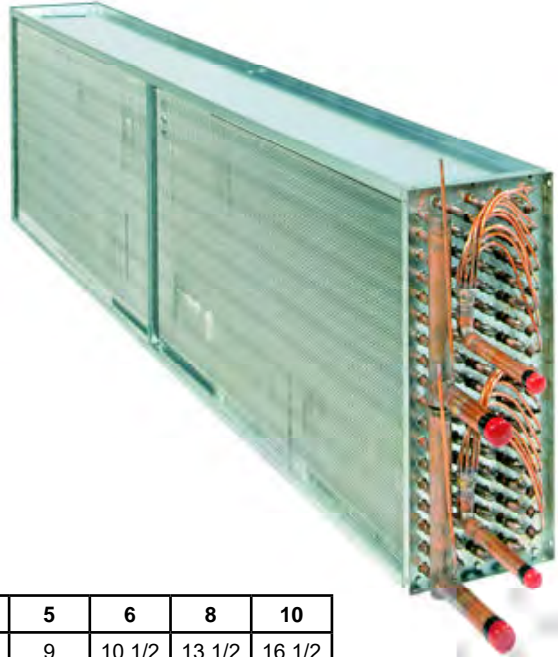

ROWS DEEP	2	3	4	5	6	8	10
DIM. 'D'	5	6	7 1/2	9	10 1/2	13 1/2	16 1/2

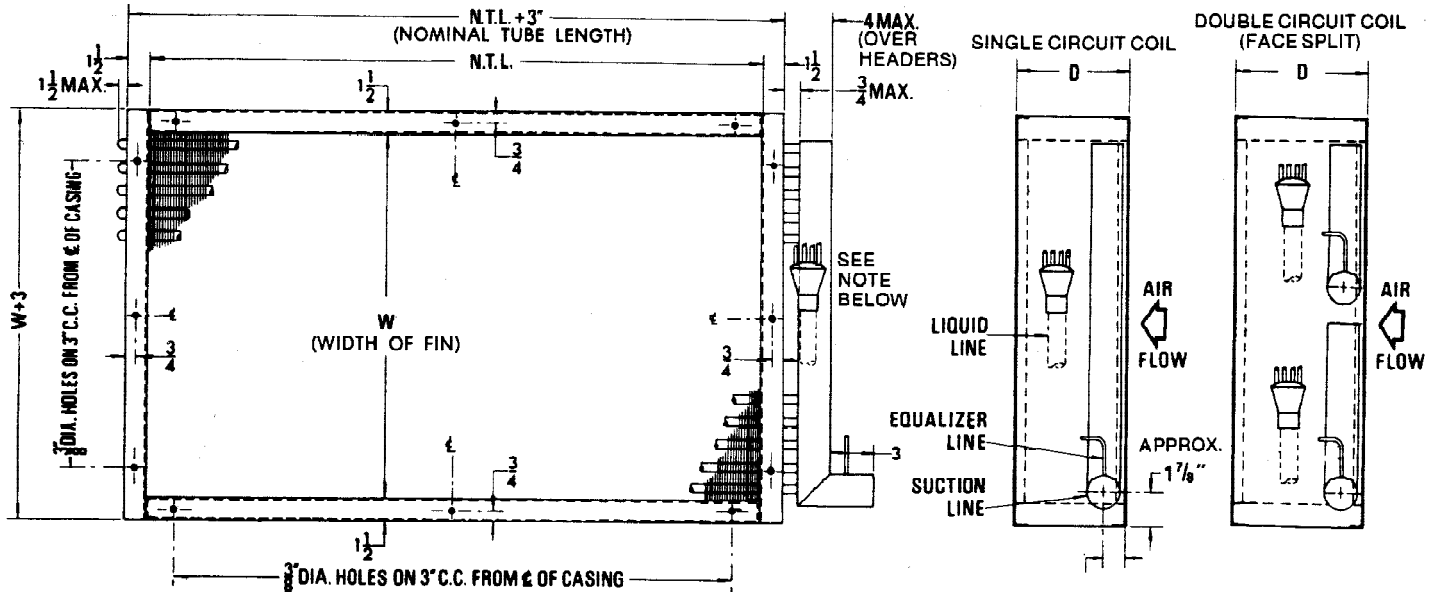

NOTE: DISTRIBUTOR MAY EXTEND BEYOND HEADER DEPENDING ON COIL SIZE.
 NOTE: R.H. COIL SHOWN ABOVE.
 ON L.H. COIL, SUCTION HEADER IS ON OPPOSITE SIDE.

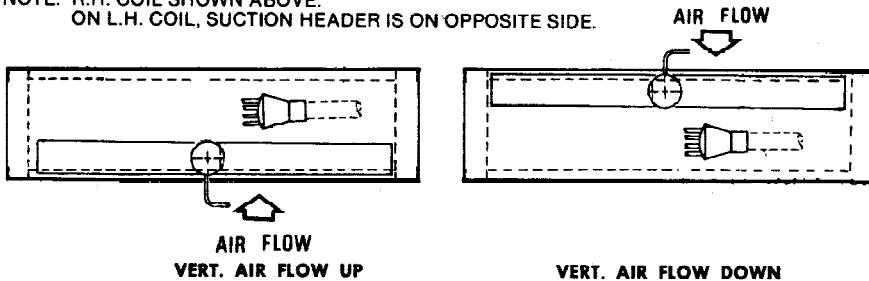

**INSTALL COILS FOR COUNTERFLOW,
 i.e. SUCTION HEADER ON ENTERING AIR SIDE**

- 5/8" TUBES**
1. Liquid conn. sizes (O.D. inches) 5/8, 7/8, 1 1/8 or 1 5/8 (dependent upon load).
 2. Suction conn. sizes (O.D. inches) 7/8, 1 5/8, 2 1/8 or 2 5/8 (located at bottom of each header section)
 3. For coils installed for horizontal air flow, specify either R.H. or L.H. connections. Handling is determined by facing into the air stream. R.H. coil will have suction conn. on R.H. side. L.H. coil will have suction conn. on L.H. side.
 4. For coils installed for vertical air flow, suction header should be on entering air side.
 5. Coils shown are not suitable for installation in Air Handling units. Consult factory for separate dimensional data.

DIMENSIONS - TH/TC COILS

INFORMATION SHOWN BELOW IS FOR GENERAL ARRANGEMENT AND DIMENSIONAL PURPOSES ONLY

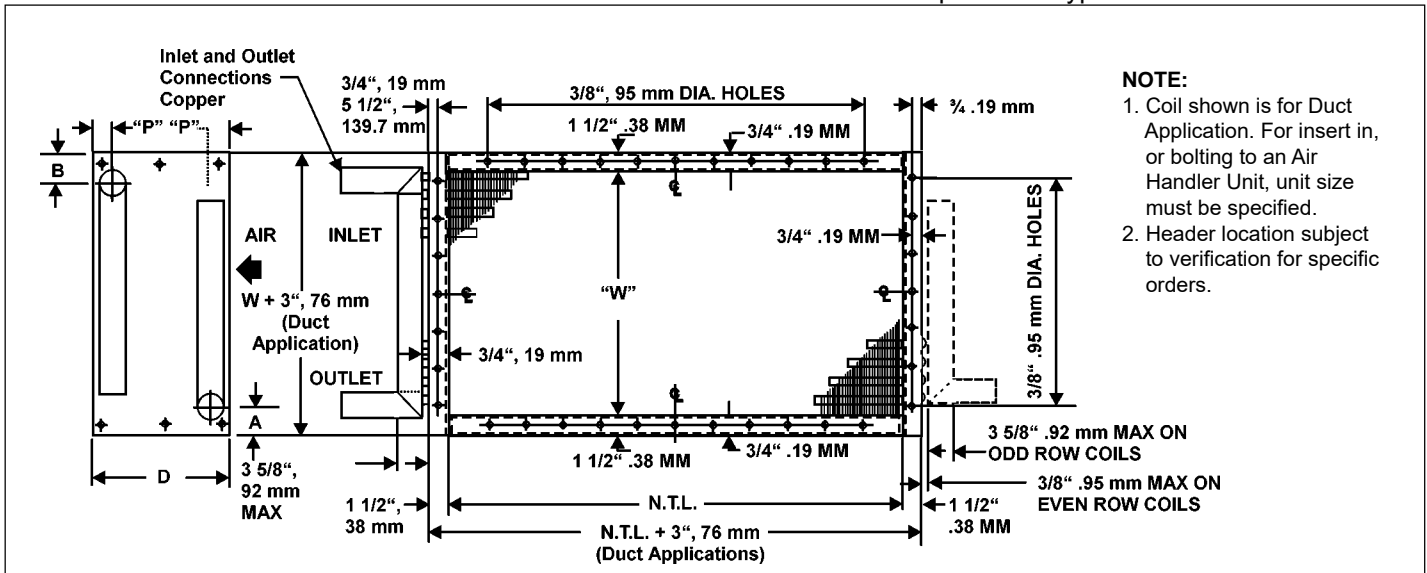

- NOTE:**
1. Coil shown is for Duct Application. For insert in, or bolting to an Air Handler Unit, unit size must be specified.
 2. Header location subject to verification for specific orders.

1/2" TUBES STANDARD

5/8" TUBES OPTIONAL

Multiple Circuit Connection Sizes* and Header Dimensions

TOTAL HEAT TONS		3 - 9	9 1/2 - 12	13 - 16	17 - 22	23 - 54	35 - 42	43 - 52	53 - 68	69 - 77
HOT GAS INLET, O.D.S.	mm	28.57	34.92	34.92	41.27	53.97	53.97	66.67	66.67	79.37
	ins	1 1/8	1 3/8	1 3/8	1 5/8	2 1/8	2 1/8	2 5/8	2 5/8	3 1/8
LIQUID OUTLET, O.D.S.	mm	22.22	22.22	28.57	28.57	34.92	41.27	41.27	53.97	53.97
	ins	7/8	7/8	1 1/8	1 1/8	1 3/8	1 5/8	1 5/8	2 1/8	2 1/8
HEADER DIM. "A"	mm	47.62	47.62	47.62	47.62	47.62	47.62	47.62	52.38	52.38
	ins	1 7/8	1 7/8	1 7/8	1 7/8	1 7/8	1 7/8	1 7/8	2 1/16	2 1/16
HEADER DIM. "B"	mm	47.62	47.62	47.62	47.62	52.38	52.38	58.73	58.73	65.08
	ins	1 7/8	1 7/8	1 7/8	1 7/8	2 1/16	2 1/16	2 5/16	2 5/16	2 9/16

Dimensional Data

ROW		2	3	4	6
DIM. "D"	mm	127.0	152.4	190.5	266.7
	ins	5	6	7 1/2	10 1/2
DIM "P"	mm	47.62	41.27	43.31	50.8
	ins	1 7/8	1 5/8	1 3/4	2

NOTE: HEADERS MAY EXTEND BEYOND DIMENSION "D"

* When used as Desuperheater, inlet and outlet connections will be the same size and based on Hot Gas sizing. Every face tube is fed on Desuperheater applications.

DIMENSIONS - TW COILS

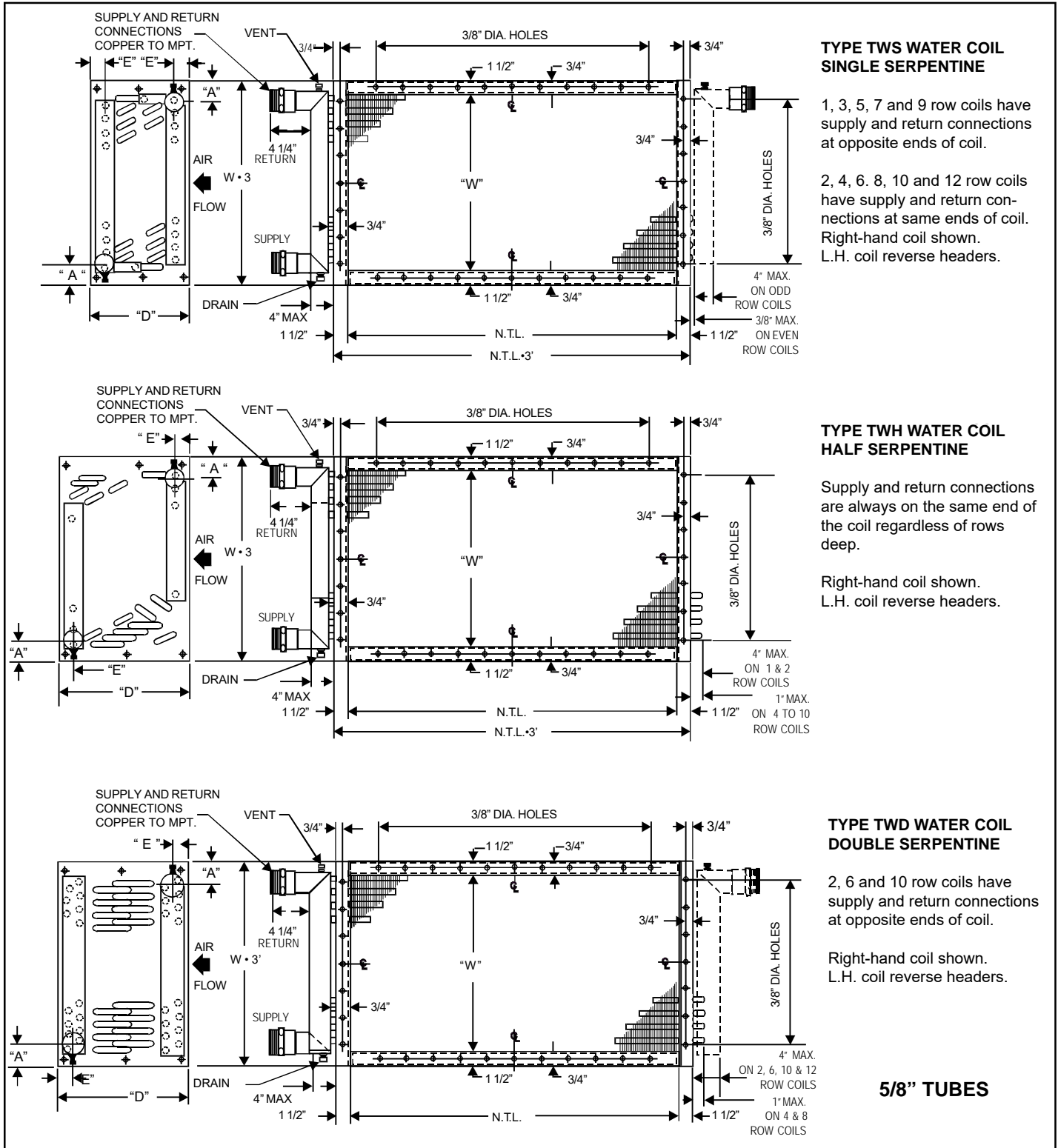

TYPE TWS WATER COIL SINGLE SERPENTINE

1, 3, 5, 7 and 9 row coils have supply and return connections at opposite ends of coil.

2, 4, 6, 8, 10 and 12 row coils have supply and return connections at same ends of coil. Right-hand coil shown. L.H. coil reverse headers.

TYPE TWH WATER COIL HALF SERPENTINE

Supply and return connections are always on the same end of the coil regardless of rows deep.

Right-hand coil shown. L.H. coil reverse headers.

TYPE TWD WATER COIL DOUBLE SERPENTINE

2, 6 and 10 row coils have supply and return connections at opposite ends of coil.

Right-hand coil shown. L.H. coil reverse headers.

5/8" TUBES

COIL DEPTH (in.)

MODEL	ROWS	1	2	3	4	5	6	7	8	9	10	12
TWS & TWH	DIM."D"	5	5	6	7 1/2	9	10 1/2	12	13 1/2	15	16 1/2	19 1/2
TWD	DIM."D"	-	5	-	7 1/2	-	10 1/2	-	13 1/2	-	16 1/2	19 1/2
TWS & TWH	DIM."E"	2 1/2	1 3/4	1 3/4	1 7/8	2	2	2 1/8	2 1/4	2 1/4	2 3/8	2 5/8
TWS & TWH	DIM."E"	2 1/2	1 3/4	1 3/4	1 7/8	2	2	2 1/8	2 1/4	2 1/4	2 3/8	2 5/8

NOTE: Headers May Extend Beyond Dimension "D"

COIL CONNECTION SIZES (in.)

TOTAL G.P.M.	0-10	11-20	21-30	31-50	51-80	81-125	126-175
HEADER AND CONN. SIZE	1	1 1/4	1 1/2	2	2 1/2	3	3 1/2
DIM. "A"	1 7/8	7/8	1 7/8	2 1/16	2 5/16	2 9/16	2 13/16

CIRCUITING - TW COILS

TYPE "TWS" COILS

Type "TWS" Coils are specifically designed and engineered to meet most applications requiring normal water quantities and normal water pressure drop. Type "TWS" Coils are counterflow, single serpentine circuited to deliver absolute maximum performance. With single serpentine coils every tube in the first row is fed as indicated in the circuiting drawing on the right.

Type "TWS" Coils of two, four, six, eight and ten rows deep are furnished with the supply and return connections on the same end of the coil.

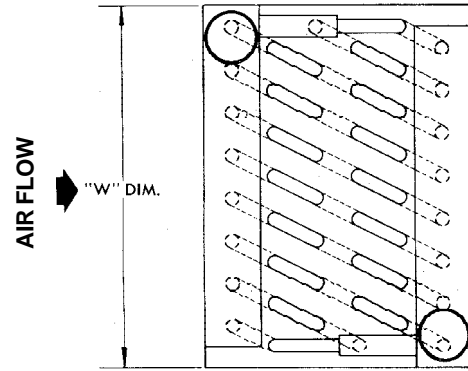

6 ROW TWS CIRCUITING
HORIZONTAL OR VERTICAL AIR FLOW

TYPE "TWD" COILS

Type "TWD" Coils are designed for use in applications that require high water quantities and low water pressure drop. "TWD" Coils are counterflow, double serpentine circuited to maintain normal water velocities and low water pressure drops. With double serpentine coils every tube in the first and second rows are fed as shown in the circuiting drawing on the right. Four and eight row coils have the supply and return connections on the same end of the coil.

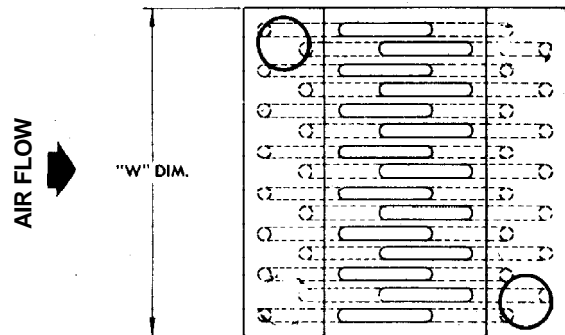

8 ROW TWD CIRCUITING
HORIZONTAL OR VERTICAL AIR FLOW

TYPE "TWH" COILS

Type "TWH" Coils are designed to produce high capacity with limited water quantity. High capacity is obtained from the counterflow half serpentine water circuiting which gives higher water velocities.

With half serpentine coils every other tube in the first row is fed as shown in the circuiting drawing on the right.

All Type "TWH" Coils, regardless of row depth, have both the supply and return connections on the same end of the coil. When ordering TWH Coils, state vertical or horizontal air flow as required.

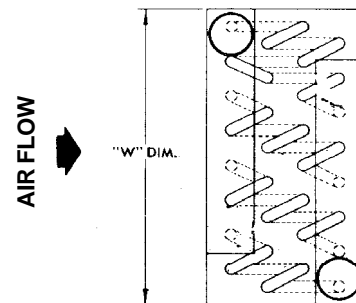

4 ROW TWH CIRCUITING
HORIZONTAL OR VERTICAL AIR FLOW

COIL CHECKLIST

The following information is required to design and select a coil:

1. COIL DATA:

FIN MATERIAL _____

ROWS DEEP _____

FPI _____

2. AIR SIDE PERFORMANCE:

CFM _____

FPM _____

3. SPECIFIC COIL DESIGN DETAILS:

REFRIGERANT TYPE _____

ALL COILS - TD _____

DIRECT EXPANSION	WATER	HEAT RECLAIM
SST	EWT	COND TEMP
CIRCUIT	LWT	TOTAL CAPACITY
	CAPACITY	RECLAIM CAPACITY
CAPACITY	GPM	CIRCUITING DATA

4. COIL HEADER LOCATION:

RIGHT OR LEFT HAND _____ (Air Blowing at you)

5. COIL TUBE DIAMETER:

INDICATE DIAMETER _____

STANDARD OR DEVIATION (select)

All coils are standard 5/8" dia. except for heat reclaim and condenser which are 1/2"

NOTES

PRODUCT SUPPORT RESOURCES

 PRODUCT SUPPORT	<p><i>web:</i> t-rp.com/coils <i>email:</i> ahu@t-rp.com <i>call:</i> 1-844-893-3222 x527</p>
 TROUBLESHOOTING	<p><i>email:</i> troubleshooting@t-rp.com <i>call:</i> 1-844-893-3222 x529</p>
 SERVICE PARTS	<p><i>web:</i> t-rp.com/parts <i>email:</i> parts@t-rp.com <i>call:</i> 1-844-893-3222 x501</p>
 WARRANTY	<p><i>web:</i> t-rp.com/warranty <i>email:</i> warranty@t-rp.com <i>call:</i> 1-844-893-3222 x501</p>
 ORDERS	<p><i>email:</i> orders@t-rp.com <i>call:</i> 1-844-893-3222 x501</p>
 SHIPPING	<p><i>email:</i> shipping@t-rp.com <i>call:</i> 1-844-893-3222 x503</p>



NATIONAL REFRIGERATION &
AIR CONDITIONING CANADA CORP.
159 Roy Blvd.
Brantford Ontario Canada N3R 7K1
PHONE: (519) 751-0444 800-463-9517
FAX (519) 753-1140 www.t-rp.com



Due to the manufacturer's policy of continuous product improvement, we reserve the right to make changes without notice.