



TPCC HORIZONTAL PRODUCT COOLERS

SPECIFICATIONS INSTALLATION, OPERATION AND MAINTENANCE MANUAL

AIR DEFROST FOR APPLICATIONS 35 °F
(1.6 °C) (ELECTRIC AND HOT GAS
DEFROST MODELS ARE OPTIONAL)
UP TO 30 TONS NOMINAL CAPACITY

BULLETIN: T30-TPCC-PDI-10
1064636

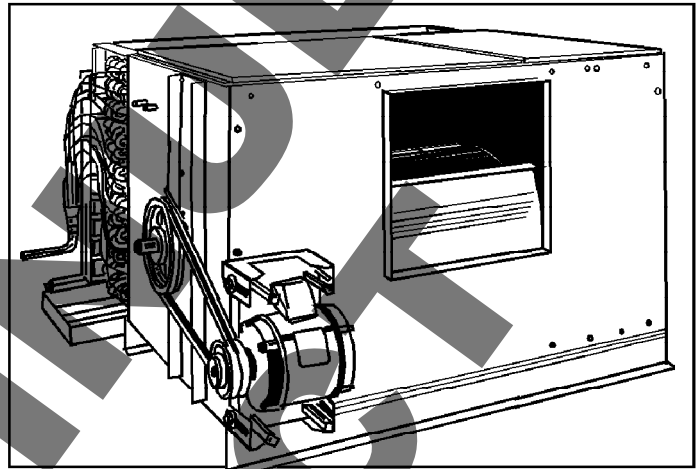

NOMENCLATURE

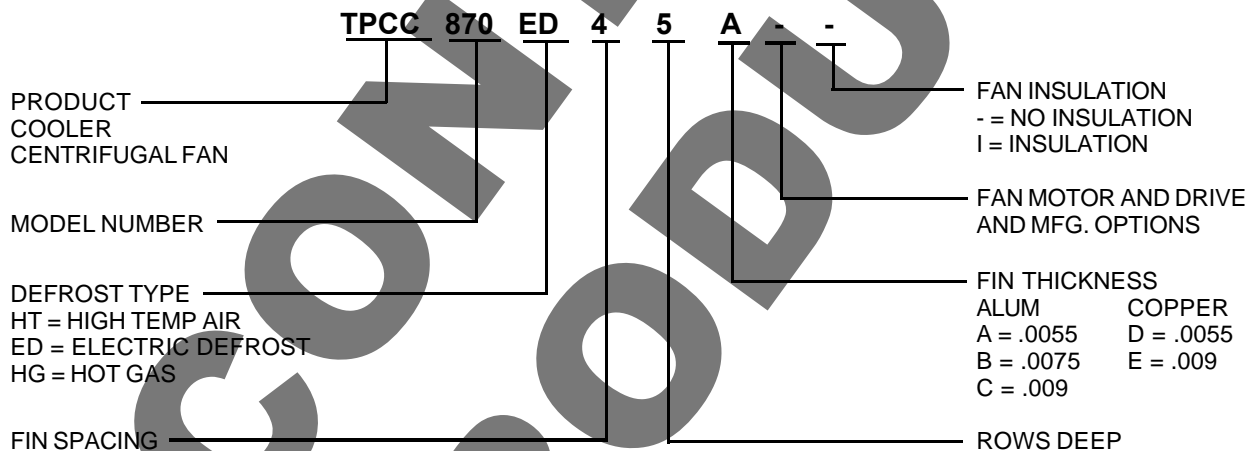

- Large face area centrifugal fan
- New "bolt-on" coil for maximum capacity in a minimum space.
- Electronically balanced high efficiency fans with forward curved blades provide quiet operation.
- Heavy gauge galvanized steel cabinet.
- Self-aligning ball bearings and heavy channel stiffeners eliminate vibration and ensure quiet operation.
- Full size access doors for easy maintenance.

CONTENTS	PAGE
Nomenclature.....	Cover
Capacity Data.....	2
Correction Factor.....	2
Blower Data.....	3
General Data.....	4
Dimensional Data.....	5, 6
Installation Instructions.....	7, Back
Service Log.....	Back
Project Information.....	Back

CAPACITY DATA

COOLING CAPACITIES - BTU / H °F T.D. ⁽¹⁾
 BASED ON 600 FPM (183m/min) FACE VELOCITY

MODEL No.	CFM * (Litre/sec.) @ 600 FPM (183m/min.)	FACE AREA SQ. FT. (m ²)	ROWS DEEP	COIL ENT. AIR FROM 32°F (0°C) to 35°F (1.6°C)			**COIL ENT. AIR BELOW 32°F (0°C)	
				FIN SPACING			FIN SPACING	
				8/INCH	6/INCH	4/INCH	6/INCH	4/INCH
				DX	DX	DX	DX	DX
TPCC 870	6,340 (2,992)	10.5 (.975)	4	3460	3210	2630	2870	2350
			6	4420	4120	3360	3800	3130
			8	5040	4670	3830	4480	3680
			10	5610	5200	4270	5020	4120
TPCC 1170	8,500 (4,012)	14.1 (1.30)	4	4630	4310	3520	3840	3150
			6	5920	5520	4510	5120	4200
			8	6750	6290	5130	6010	4930
			10	7500	6980	5730	6740	5510
TPCC 1470	10,650 (5,026)	17.7 (1.64)	4	5810	5400	4410	4820	3940
			6	7410	6940	5650	6400	5250
			8	8450	7880	6450	7530	6170
			10	9400	8740	7170	8440	6920
TPCC 1770	12,800 (6,041)	21.3 (1.97)	4	6980	6510	5310	5790	4750
			6	8940	8310	6800	7690	6330
			8	10160	9450	7750	9070	7410
			10	11300	10500	8620	10150	8290
TPCC 2270	15,700 (7,410)	26.2 (2.43)	4	8560	7960	6530	7120	5830
			6	10920	10180	8330	9420	7750
			8	12490	11560	9500	11100	9080
			10	13870	12890	10580	12450	10180
TPCC 2870	19,600 (9,250)	32.6 (3.02)	4	10480	9950	8120	8860	7270
			6	13630	12730	10400	11820	9660
			8	15560	14440	11820	13870	11360
			10	17260	16120	13180	15450	12720
TPCC 3770	26,150 (12,341)	43.6 (4.05)	4	14270	13240	10850	11880	9710
			6	18280	17000	13920	15750	12890
			8	20780	19290	15750	18480	15170
			10	23060	21470	17580	20660	16880
TPCC 4170	29,800 (14,064)	49.6 (4.60)	4	16250	15110	12310	13460	10990
			6	20760	19360	15770	17830	14630
			8	23660	21900	17950	21040	17150
			10	26270	24420	20050	23480	19240
TPCC 5070	34,900 (16,471)	58.1 (5.39)	4	19000	17650	14460	15790	12920
			6	24320	22610	18430	20980	17220
			8	27740	25750	21090	24610	20200
			10	30780	28600	23420	27600	22610
TPCC 6470	43,600 (20,577)	72.6 (6.74)	4	23700	22040	18050	19780	16090
			6	30450	28260	23040	26170	21520
			8	34680	32210	26320	30880	25220
			10	38480	35720	29360	34580	28240

* For Applications in room temperatures above 35 °F (1.6 °C) maximum face velocity should not exceed 500 FPM (152m/min) and capacities corrected accordingly (see table 1 for correction factors).

** These ratings are based on moderate coil frosting. For heavy frosting use factor of 0.95.

(1) "T.D." - Represents the difference between temperature of air entering cooling coil and coil refrigerant temperature.

Ratings for units using electric defrost may be determined by multiplying ratings in above table by 0.95

**FACE VELOCITY CAPACITY CORRECTION FACTORS
TABLE 1**

Face Velocity F.P.M. (m/min.)	Rows Deep In Direction Of Airflow			
	4	6	8	10
600 (183)	1.0	1.0	1.0	1.0
500 (152)	.91	.90	.89	.89
400 (122)	.80	.78	.76	.73

BLOWER DATA

FAN RPM AND MOTOR HP REQUIREMENTS

TPCC MODEL	FACE VELOCITY FPM (m/min.)	CFM (litre/sec.)	TOTAL STATIC PRESSURE (INCHES - WATER GAUGE)																	
			TSP=.125"		TSP=.25"		TSP=.50"		TSP=.75"		TSP=1.00"		TSP=1.25"		TSP=1.50"		TSP=1.75"			
			RPM	BHP	RPM	BHP	RPM	BHP	RPM	BHP	RPM	BHP	RPM	BHP	RPM	BHP	RPM	BHP		
870	400 (122)	4,220 (1,992)	440	0.56	475	0.66	542	0.84	608	1.04	676	1.28	744	1.52	810	1.77	870	2.03		
	500 (152)	5,290 (2,497)	530	1.09	560	1.19	613	1.39	667	1.63	722	1.90	778	2.16	833	2.44	887	2.73		
	600 (183)	6,340 (2,992)	630	1.72	650	1.94	697	2.18	740	2.44	785	2.72	830	3.01	878	3.32	925	3.65		
1170	400 (122)	5,670 (2,676)	438	0.98	465	1.08	522	1.29	580	1.55	635	1.87	692	2.20	751	2.53	807	2.88		
	500 (152)	7,090 (3,346)	533	1.87	560	1.98	600	2.20	640	2.47	682	2.78	738	3.14	780	3.54	828	3.94		
	600 (183)	8,500 (4,012)	621	3.18	640	3.31	679	3.57	716	3.85	754	4.17	792	4.52	830	4.92	872	5.35		
1470	400 (122)	7,100 (3,351)	515	1.11	555	1.26	637	1.57	716	1.89	801	2.24	865	2.61	934	3.00	1000	3.42		
	500 (152)	8,800 (4,153)	612	2.00	648	2.20	718	2.59	784	2.97	848	3.36	912	3.76	973	4.19	1033	4.65		
	600 (183)	10,650 (5,026)	730	3.43	758	3.68	815	4.17	867	4.63	928	5.09	980	5.55	1035	6.02	1086	6.51		
1770	400 (122)	8,540 (4,030)	470	1.29	490	1.46	565	1.81	637	2.21	707	2.64	775	3.09	839	3.57	900	4.01		
	500 (152)	10,680 (5,040)	562	2.38	580	2.60	640	3.04	700	3.49	757	3.96	813	4.47	869	5.01	924	5.57		
	600 (183)	12,800 (6,041)	653	3.96	669	4.23	723	4.77	773	5.30	822	5.84	870	6.39	918	6.97	966	7.58		
2270	400 (122)	10,480 (4,946)	423	1.60	447	1.82	513	2.25	579	2.74	642	3.26	704	3.82	762	4.40	817	5.01		
	500 (152)	13,100 (6,183)	508	2.98	530	3.24	584	3.77	637	4.33	688	4.91	741	5.54	791	6.20	840	6.89		
	600 (183)	15,700 (7,410)	591	5.03	614	5.34	663	5.97	709	6.62	751	7.27	796	7.97	840	8.67	881	9.44		
2870	400 (122)	13,060 (6,164)	308	1.65	339	1.95	400	2.56	457	3.23	513	3.96	565	4.72	614	5.49	661	6.28		
	500 (152)	16,330 (7,707)	365	3.02	395	3.40	447	4.17	495	4.94	542	5.75	587	6.62	632	7.52	686	8.46		
	600 (183)	19,600 (9,250)	442	4.98	454	5.45	500	6.39	542	7.30	581	8.22	620	9.17	661	10.17	697	11.21		
3770	400 (122)	17,440 (8,231)	302	2.47	322	2.87	373	3.66	422	4.52	468	5.41	513	6.35	556	7.32	596	8.31		
	500 (152)	21,800 (10,289)	370	4.58	392	5.05	420	5.99	456	7.00	496	8.05	535	9.14	573	10.27	610	11.42		
	600 (183)	26,150 (12,341)	411	7.69	432	8.24	471	9.35	507	10.49	541	11.69	574	12.92	607	14.21	639	15.53		
4170	400 (122)	19,860 (9,373)	204	2.84	220	3.33	259	4.31	293	5.26	324	6.21	353	7.22	382	8.27	408	9.36		
	500 (152)	24,820 (11,714)	238	5.15	255	5.79	290	7.08	321	8.29	351	9.48	375	10.65	400	11.86	423	13.09		
	600 (183)	29,800 (14,064)	278	8.59	293	9.38	323	10.97	352	12.49	378	14.28	401	15.39	424	16.81	446	18.20		
5070	400 (122)	23,250 (10,973)	173	3.00	190	3.54	227	4.67	260	5.72	290	6.88	317	8.10	342	9.36	367	10.67		
	500 (152)	29,060 (13,715)	205	5.49	221	6.15	251	7.48	280	8.83	308	10.20	333	11.61	356	13.06	380	14.55		
	600 (183)	34,900 (16,471)	243	8.15	254	9.94	280	11.53	300	13.14	330	14.76	352	16.40	374	18.05	396	19.74		
6470	400 (122)	29,060 (13,715)	165	3.96	178	4.68	210	6.13	238	7.54	264	8.96	288	10.42	312	11.94	335	13.53		
	500 (152)	36,330 (17,146)	191	7.20	205	8.10	234	9.90	260	11.71	283	13.48	305	15.24	325	17.01	345	18.80		
	600 (183)	43,600 (20,577)	223	11.90	235	13.08	260	15.19	284	17.38	306	19.61	326	21.70	344	23.81	362	25.92		

INTERNAL AIRSIDE RESISTANCE - INCHES, W. G.

Coil Rows Deep	COIL FACE VELOCITY FPM (m/min)								
	400 (122)			500 (152)			600** (183)		
	Fins Per Inch								
	4	6	8	4	6	8	4	6	8
4	.09	.12	.14	.13	.17	.20	.18	.23	.27
5	.12	.14	.16	.17	.21	.25	.23	.28	.34
6	.13	.16	.20	.20	.25	.30	.27	.34	.41
8	.18	.23	.27	.27	.34	.41	.35	.44	.53
10	.23	.28	.34	.34	.42	.51	.45	.56	.68
12	.27	.34	.41	.39	.49	.59	.53	.67	.81

** Coil face velocity should not exceed 500 FPM (152 m/min.) for applications where room temperature is above 35 °F (1.6 °C).

WET COIL CORRECTION FACTOR*

Ent. Air Dew Point Minus Refr. Temp.	
10°F (5.5°C) or Less	11°F (6.1°C) to 18°F (10°C)
1.12	1.24

* For medium frosted coil, use factor of 1.3

Example:
 600 FPM (183 m/min.), 8 row coil 4 fins/in.
 Evap. Temp. 40 °F (4.4 °C)
 Ent. Air Dew Point 45 °F (7.2 °C)
 Internal Airside Resistance - .35
 Wet Coil Correction factor = 1.12
 Total Internal Airside Resistance = 1.12 x .35 = .392

GENERAL DATA

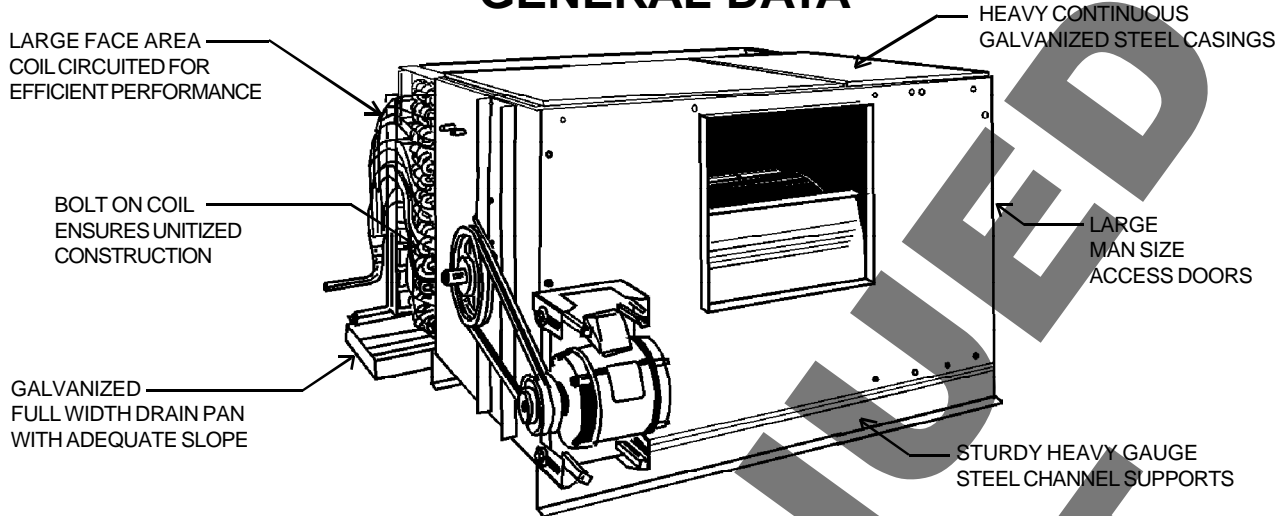

PHYSICAL DATA

MODEL NUMBER		TPCC 870	TPCC 1170	TPCC 1470	TPCC 1770	TPCC 2270	TPCC 2870	TPCC 3770	TPCC 4170	TPCC 5070	TPCC 6470
FAN DATA											
- No.		1	1	2	2	2	2	2	1	1	1
- Dia.	ins.	15	16 1/2	13 1/2	15	16 1/2	20	22 1/4	33	36 1/2	40 1/4
	mm	381	419.1	342.9	381	419.1	508	565.1	838.2	927.1	1022.3
Outlet Area	sq. ft.	2.82	3.45	4.65	5.63	6.90	10.26	12.42	13.79	16.77	20.48
	m ²	.261	.320	.431	.523	.731	.953	1.15	1.28	1.55	1.90
COIL DATA: Face Size	ins.	34 1/2 x 44	34 1/2 x 59	34 1/2 x 74	34 1/2 x 89	40 1/2 x 93	40 1/2 x 116 1/4	52 1/2 x 116 1/4	61 1/2 x 116 1/4	72 x 116 1/4	90 x 116 1/4
	mm	876 x 1118	876 x 1499	876 x 1880	876 x 2261	1029 x 2362	1029 x 2953	1334 x 2953	1562 x 2953	1829 x 2953	2286 x 2953
Face Area	sq. ft.	10.5	14.1	17.7	21.3	26.2	32.6	43.6	49.6	58.1	72.6
	m ²	.975	1.30	1.64	1.97	2.43	3.02	4.05	4.60	5.39	6.74
ELECTRIC DEFROST * KW. REQUIREMENTS											
Rows Deep	4	6.1	7.1	8.6	12.1	13.8	17.3	17.3	19.6	21.9	26.3
	6	6.1	7.1	8.6	12.1	13.8	17.3	17.3	19.6	21.9	26.3
	8	7.1	9.1	11.1	13.6	15.6	21.8	21.8	24.1	28.6	35.3
	10	9.1	11.1	13.6	16.6	19.1	26.3	26.3	30.8	35.3	44.3
HOT GAS DEFROST DRAIN PAN CONNS.		ALL SIZES 1-5/8" (41 mm) O.D. COPPER									

* Defrost heaters rated for 230 volt or 575 volt operation.

SHIPPING WEIGHTS

MODEL NUMBER	TPCC 870	TPCC 1170	TPCC 1470	TPCC 1770	TPCC 2270	TPCC 2870	TPCC 3770	TPCC 4170	TPCC 5070	TPCC 6470
*Fan Section	550 lbs.	600 lbs.	750 lbs.	850 lbs.	1,000 lbs.	1,270 lbs.	1,640 lbs.	1,950 lbs.	2,700 lbs.	3,610 lbs.
Drive and Motor	249.4 kg	272.1 kg	340.1 kg	385.5 kg	453.5 kg	576 kg	743.8 kg	884.5 kg	1224.6 kg	1637.4 kg

* This weights are for fan section, drive and motor only. Coil weights must be added to the weights shown above.

COIL WEIGHTS	The weight of the copper / aluminium coils may be calculated on the basis of 6 lbs. (2.7 kg) per square ft. face area / row deep.
---------------------	---

Note: Metric figures are approximate to eliminate excessive decimals.

DIMENSIONAL DATA

MODELS TPCC 870 THRU TPCC 2870

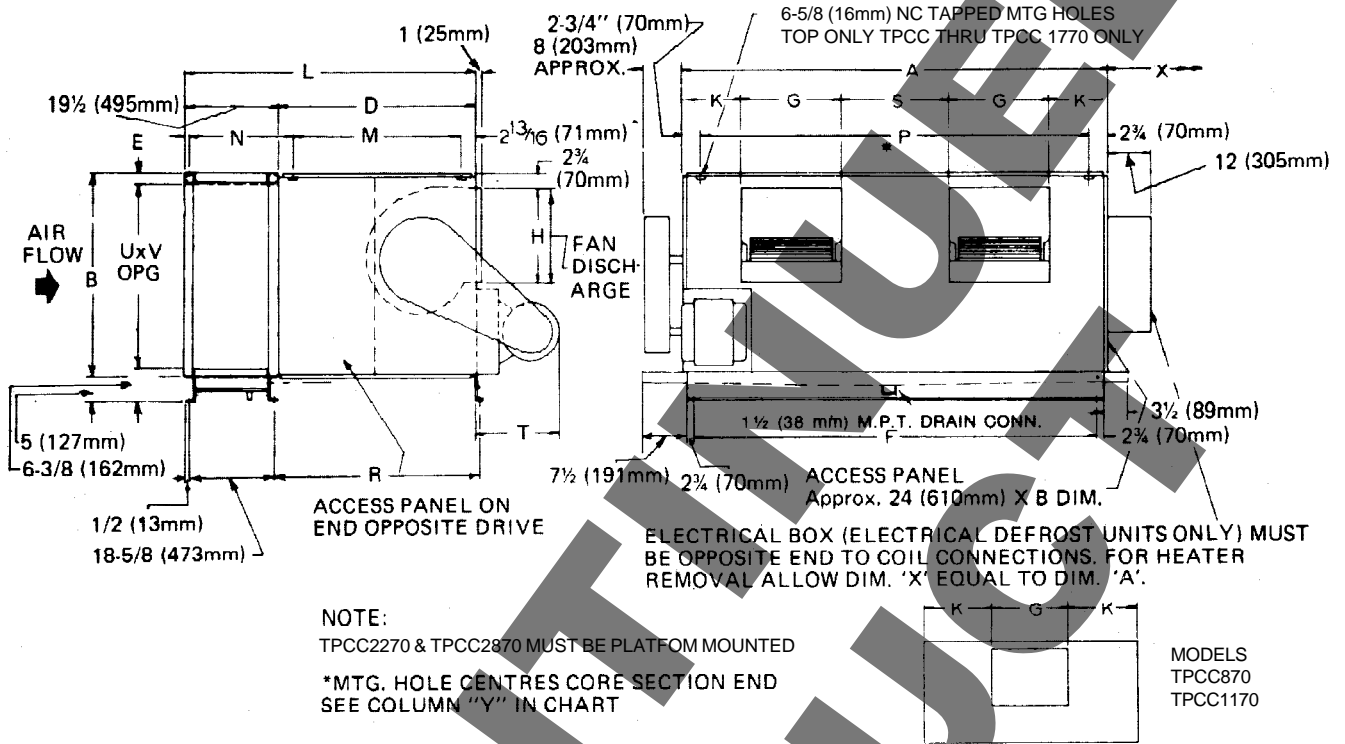

MODELS TPCC 3770 THRU TPCC 6470

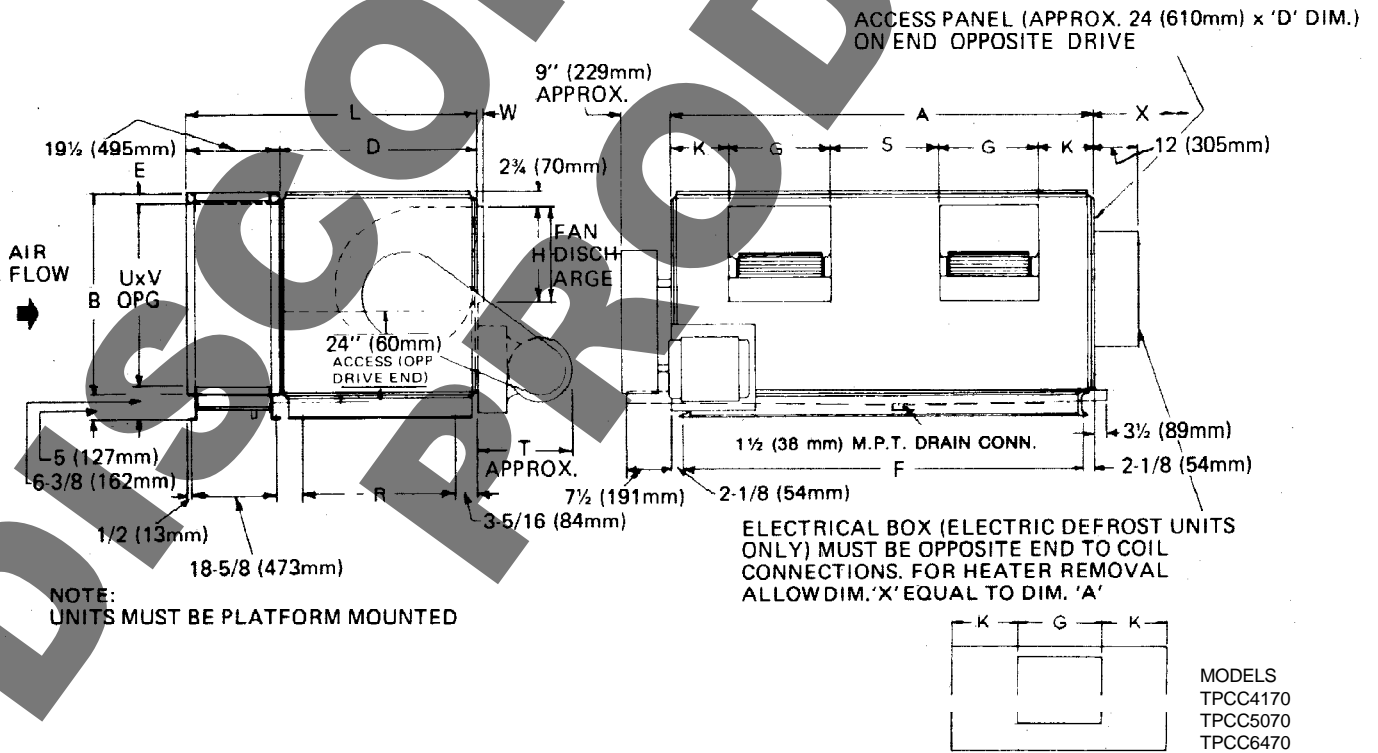

Note: Metric figures are approximate to eliminate excessive decimals.

DIMENSIONAL DATA

Model No.		A	B	D	E	F	G	H	K	L	M	N	P	R	S	T	U	V	Y
TPCC 870	ins	48	37 3/4	36 3/4	1 1/2	42 1/2	21 1/8	19 3/4	13 7/16	56 1/4	31 1/8	20 3/8	42 1/2	37 3/4	-	18	33 1/8	44 1/8	38 1/2
	mm	1219.2	958.9	933.4	38.1	1079.5	536.5	492.1	341.3	1428.7	790.5	517.5	1079.5	958.8	-	457.2	841.3	1120.7	977.9
TPCC 1170	ins	63	37 3/4	36 3/4	1 1/2	57 1/2	23 1/4	21 1/2	19 7/8	56 1/4	31 1/8	20 3/8	57 1/2	37 3/4	-	18	33 1/8	59 1/8	53 1/2
	mm	1600.2	958.9	933.4	38.1	1460.5	590.5	546.1	504.8	1428.7	790.5	517.5	1460.5	958.8	-	457.2	841.3	1501.7	1358.9
TPCC 1470	ins	78	37 3/4	36 3/4	1 1/2	72 1/2	19	17 7/8	10	56 1/4	31 1/8	20 3/8	72 1/2	37 3/4	20	21	33 1/8	74 1/8	68 1/2
	mm	1981.2	958.9	933.4	38.1	1841.5	482.6	454	254	1428.7	790.5	517.5	1841.5	958.8	508	533.4	841.3	1882.7	1739.9
TPCC 1770	ins	93	37 3/4	36 3/4	1 1/2	87 1/2	21 1/8	19 3/8	12 11/16	56 1/4	31 1/8	20 3/8	87 1/2	37 3/4	25 3/4	21	33 1/8	89 1/8	83 1/2
	mm	2362.2	958.9	933.4	38.1	2222.5	536.5	492.1	322.1	1428.7	790.5	517.5	2222.5	958.8	644.5	533.4	841.3	2263.7	2120.9
TPCC 2270	ins	97	44 3/4	43 3/4	2 1/2	91 1/2	23 1/4	21 5/8	12 5/8	63 1/4	-	-	-	44 3/4	25 1/4	21	39 1/8	93 1/8	-
	mm	2463.8	1136.7	1111.2	63.5	2324.1	590.5	549.2	320.6	1606.5	-	-	-	1136.6	641.3	533.4	993.7	2365.3	-
TPCC 2870	ins	120	44 3/4	43 3/4	2 1/2	114 1/2	28 3/16	26 1/2	15 29/32	63 1/4	-	-	-	44 3/4	31 13/16	23	39 1/8	116 1/4	-
	mm	3048.0	1136.7	1111.2	63.5	2908.3	715.9	673.1	404.0	1606.5	-	-	-	1136.6	808.0	584.2	993.7	2952.7	-
TPCC 3770	ins	122 1/8	57 1/2	45 5/8	2 1/2	117 7/8	31 7/16	28 3/4	15 5/32	65 1/8	-	-	-	39 1/2	29 1/16	25	51 7/8	116 1/4	-
	mm	3101.9	1460.5	1158.8	63.5	2994	798.5	730.2	384.9	1654.1	-	-	-	1003.2	738.1	635	1317.6	2952.7	-
TPCC 4170	ins	122 1/8	65 3/4	59 1/8	2 1/2	117 7/8	46 3/8	43 1/4	37 7/8	78 5/8	-	-	-	53	-	25	60 1/8	116 1/4	-
	mm	3101.9	1670	1501.7	63.5	2994	1177.9	1098.5	902	1997.1	-	-	-	1346.2	-	635	1527.1	2952.7	-
TPCC 5070	ins	122 1/8	75 1/2	66 5/8	1 3/4	117 7/8	51 1/2	47 1/4	35 5/16	86 1/8	-	-	-	60 1/2	-	25	70 5/8	116 1/4	-
	mm	3101.9	1917.7	1692.2	44.4	2994	1308.1	1200.1	896.9	2187.5	-	-	-	1536.7	-	635	1793.8	2952.7	-
TPCC 6470	ins	122 1/8	93 1/2	72 5/8	1 3/4	117 7/8	56 3/4	52 3/8	32 11/16	92 1/8	-	-	-	66 1/2	-	25	88 5/8	116 1/4	-
	mm	3101.9	2374.9	1844.6	44.4	2994	1441.4	1330.3	830.1	2339.9	-	-	-	1689.1	-	635	2251.1	2952.7	-

DIMENSIONAL DATA

DIMENSIONAL DATA

MODELS
TPCC 870 THRU TPCC 2870

MODELS
TPCC 3770 THRU TPCC 6470

STANDARD ON ALL MODELS

Note: All units viewed from drive end.

1, 2, 3 & 4 indicate available motor locations. Standard access panel is opposite drive end. Additional access panels available at locations A, B or C.

* Not Available on units TPCC 2270 and TPCC 2870.

INSTALLATION INSTRUCTIONS

GENERAL

The Product cooler should be carefully inspected for damage when received. Visible or concealed damage should be reported immediately to the carrier and a claim filed for damage.

Product coolers are constructed from heavy gauge galvanized steel and are thoroughly inspected before leaving the plant. Care should be taken during installation to prevent damage to the units.

Care should be taken to ensure that sufficient access is available for servicing of the unit. Space should be available for lubrication, belt adjustment and coil removal.

Fans and fan shafts should be inspected before start-up. Fans are inspected before leaving the plant; however, rough handling may cause misalignment.

LOCATING AND INSTALLATION HINTS

IMPORTANT: Product Coolers TPCC3770, TPCC4170, TPCC5070 and TPCC6470 **MUST** be platform or floor mounted.

Product Coolers may be placed in any suitable manner in the room. However, low temperature units **should not** be located over entrance doors, because of the heavy frosting that will occur on the coils.

All Product Coolers must be installed level to ensure proper drainage of water from the pre-engineered drain pan.

Drain lines for all Product Cooler Models should be pitched 45° and should be as short as possible. To prevent drain line freezing problems the following recommendations should be carried out:

- (a) Use a drain line heater (supplied by others) with a density of 20 watts per foot. Six to eight feet of cable per foot of drain line is recommended.
- (b) Drain line heater should **make at least** a full turn round the outlet of the drain pan.
- (c) The heated drain line should be insulated.
- (d) The drain line should be provided with a trap outside the freezer room. Traps should be filled with water before initial start-up.

DEFROSTING

Product Coolers are obtainable with electric or hot gas defrost systems. On hot gas defrost units, the

distributor on the evaporator coil is equipped with a side port connection to facilitate a hot gas connection. Distributor tubes are oversized for hot gas operation.

A liquid line solenoid valve (supplied by others) should be used so that evaporator coil may be pumped out before each defrost cycle.

The following defrost control (supplied by others) methods may be used with Product Coolers.

(1) TIME INITIATED-TEMPERATURE TERMINATED

When using a time initiated - temperature terminated method of defrosting a Paragon Timer 8145-20 or equal is recommended for this application. Timer is used in conjunction with a defrost termination thermostat. For 3 phase applications, the timer must be used with a contactor. As well as the defrost termination thermostat, the timer will also have a fail safe feature built into unit.

The defrost termination thermostat should be set at approx. 35 °F (1.6 °C) and should be adjustable. Differential should be 5 °F (2.8 °C) or less. Bulb should be attached to a tube of the evaporator. As a part of this system, a fan delay thermostat should be used to provide a delay period between the end of the defrost and the start-up of the fan. The fan delay thermostat should be adjustable and set at 10-25 °F (5.6-13.9 °C) (depending on application) and bulb should be attached to evaporator tube. When installing thermostats, care should be taken to ensure that bulbs are not attached to evaporator heater tubes.

(2) TIME CONTROLLED OPERATION

Defrosting may also be carried out by a time controlled sequence. This system utilizes a timer and fan delay thermostat. Timer should have an adjustable length of defrost from 2-110 minutes and should be Paragon 8045-20 or equal. Fan delay thermostat should be as indicated in (1) above.

Initially, 4-30 minute defrost per day are recommended. However, it is important that the coil be completely cleared of defrost at the end of the cycle. Should coil not be cleared of all frost at the end of 30 minutes, more frequent defrost of shorter duration should be used.

WIRING

For suggested wiring of defrost heaters see Drg. No. 41594D furnished with Product Cooler.

INSTALLATION INSTRUCTIONS

START - UP

- (a) Before start-up equipment, the amperage of all electric defrost heaters, including drain pan heaters, motor, etc. should be checked to ensure satisfactory operation.
- (b) Leak test entire system and make sure all joints are tight.
- (c) Check fan and motor for correct rotation.
- (d) Check alignment of fan and motor sheave and belt tension. Belts should have approx. 1" deflection.

will have grease fittings located on unit panel. Specific greasing instructions should be carried out in accordance with tags and labels attached to unit. Care should be taken not to over lubricate. Grease should be applied when unit is running, adding slowly until there is a slight bleeding of the grease at the seals.
For continuous operation in clean areas, in an operating temperature range from -40 °F (-4 °C) to 140 °F (60 °C), normal lubrication interval is six months.

ARMVAC 781, available from both Standard Oil Company and Imperial Oil Company is the recommended lubricant for all product cooler shaft bearings.

PERIODIC SERVICE AND MAINTENANCE

- 1. Check all moving parts every six months for wear.
- 2. Check bearing collar set screws for tightness every six months.
- 3. Fan bearings are pre-lubricated and do not require lubrication at time of installation. Extended lube lines

REPLACEMENT PARTS

When replacement parts are required on units manufactured by Trenton Refrigeration, furnish factory with unit model number and serial number as shown on serial plate on drive end blower section.

SERVICE LOG

DATE	COMMENTS

PROJECT INFORMATION

System	
Model Number	Date of Start-Up
Serial Number	Service Contractor
Refrigerant	Phone
Electrical Supply	Fax



NATIONAL REFRIGERATION & AIR CONDITIONING CANADA CORP.
 159 Roy Blvd. • Brantford • Ontario, Canada N3T 5Y6
 Phone (519) 751-0444 • 800-463-9517 • Fax: (519) 753-1140