



TM

# JUCT MEDIUM PROFILE UNIT COOLER

## SPECIFICATIONS INSTALLATION, OPERATION AND MAINTENANCE MANUAL

### HIGH TEMP APPLICATIONS

(+35°F ROOM TEMP. OR HIGHER)

### AIR DEFROST

### ELECTRICAL POWER:

SINGLE & THREE PHASE

BULLETIN: T30-JUCTA-PDI-14

1047752

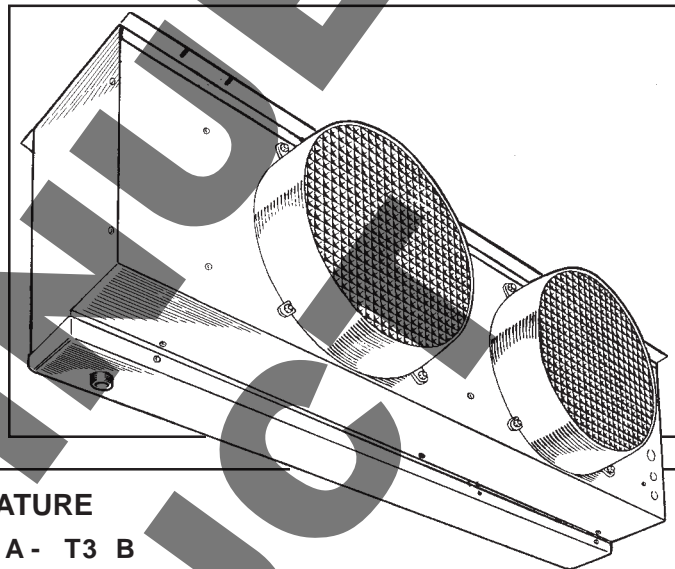

### NOMENCLATURE

JUCT 1 30 - A - T3 B

TRENTON MEDIUM PROFILE  
UNIT COOLER

NUMBER OF FANS

MBH CAPACITY AT 10 °F TD (60Hz)  
30 = 30,000 BTUH

DEFROST  
A = DEFROST

REVISION LEVEL

#### ELECTRICAL

S2 = 208-230/1/60

T3 = 208-230/3/60

T5 = 575/3/60

T8 = 380/3/60

S6 = 200-220/1/50

T4 = 460/3/60

T7 = 200-220/3/50

T9 = 380-400/3/50

- \* Heavy gauge textured aluminum cabinet construction resists scratches/corrosion and minimizes weight for shipment, installation and service.
- \* Attractive and durable high density polyethylene fan guards with built-in throw boosters.
- \* 3/8 Tubing coil construction (reduces operating charge).
- \* VENTURI-FLO Distributor eliminates need for distributor nozzle selections.
- \* Refrigerants R12, R22, R502, R134a, R404A, R407A, R407B, R407C, R507.

### CONTENTS

	PAGE
Nomenclature.....	Cover
Capacity Data.....	2
Electrical Data.....	2,3
Wiring Diagrams.....	4
Dimensional Data.....	5
Pictorial Views.....	6
Expansion valve Selection.....	6
Application.....	7
Installation.....	7
Inspection.....	7
Location.....	7
Mounting.....	7
Drain Line.....	7
Wiring.....	7
System Check.....	7
Maintenance.....	7
Service Parts List.....	Back
Project Information.....	Back

# JUCT MEDIUM PROFILE SPECIFICATIONS

## CAPACITY DATA (BTUH)

High Temp Model	JUCT	120A	125A	131A	239A	247A	254A	263A	374A	383A	393A
Capacity 1 °F T. D.	BTUH	2,000	2,500	3,100	3,900	4,700	5,400	6,300	7,400	8,300	9,300
Capacity 10 °F T. D.	BTUH	20,000	25,000	31,000	39,000	47,000	54,000	63,000	74,000	83,000	93,000
Capacity 15 °F T. D.	BTUH	30,000	37,500	46,500	58,500	70,500	81,000	94,500	111,000	124,500	139,500
CFM	cfm	3,000	4,700	4,550	9,400	9,400	9,100	9,100	13,650	13,650	13,150
Refrigerant Charge*	Lbs.	6.8	6.1	9	8.9	11.8	14.9	17.9	17.7	23	26.5
Approx. Shipping Wt.	Lbs.	160	190	205	350	370	380	390	540	560	580

\* R22 at +20°F S.S.T. with coil 30% full

## ELECTRICAL DATA - FAN MOTORS 60HZ

208-230/1/60					208-230/3/60				
MODEL	FAN MOTOR QTY	FAN FLA TOTAL	MIN. CIRC. AMPACITY (A)	MAX. FUSE (AMPS)	MODEL	FAN MOTOR QTY	FAN FLA TOTAL	MIN. CIRC. AMPACITY (A)	MAX. FUSE (AMPS)
JUCT120P-A-S2B	1	3.3	4.13	15	JUCT120P-A-T3B	1	2.0	2.5	15
JUCT125P-A-S2B	1	3.3	4.13	15	JUCT125P-A-T3B	1	2.0	2.5	15
JUCT131P-A-S2B	1	3.3	4.13	15	JUCT131P-A-T3B	1	2.0	2.5	15
JUCT239P-A-S2B	2	6.6	7.43	15	JUCT239P-A-T3B	2	4.0	4.5	15
JUCT247P-A-S2B	2	6.6	7.43	15	JUCT247P-A-T3B	2	4.0	4.5	15
JUCT254P-A-S2B	2	6.6	7.43	15	JUCT254P-A-T3B	2	4.0	4.5	15
JUCT263P-A-S2B	2	6.6	7.43	15	JUCT263P-A-T3B	2	4.0	4.5	15
JUCT374P-A-S2B	3	9.9	10.73	15	JUCT374P-A-T3B	3	6.0	6.5	15
JUCT383P-A-S2B	3	9.9	10.73	15	JUCT383P-A-T3B	3	6.0	6.5	15
JUCT393P-A-S2B	3	9.9	10.73	15	JUCT393P-A-T3B	3	6.0	6.5	15

460/3/60					575/3/60				
MODEL	FAN MOTOR QTY	FAN FLA TOTAL	MIN. CIRC. AMPACITY (A)	MAX. FUSE (AMPS)	MODEL	FAN MOTOR QTY	FAN FLA TOTAL	MIN. CIRC. AMPACITY (A)	MAX. FUSE (AMPS)
JUCT120P-A-T4B	1	1.0	1.25	15	JUCT120P-A-T5B	1	0.8	1	15
JUCT125P-A-T4B	1	1.0	1.25	15	JUCT125P-A-T5B	1	0.8	1	15
JUCT131P-A-T4B	1	1.0	1.25	15	JUCT131P-A-T5B	1	0.8	1	15
JUCT239P-A-T4B	2	2.0	2.25	15	JUCT239P-A-T5B	2	1.6	1.8	15
JUCT247P-A-T4B	2	2.0	2.25	15	JUCT247P-A-T5B	2	1.6	1.8	15
JUCT254P-A-T4B	2	2.0	2.25	15	JUCT254P-A-T5B	2	1.6	1.8	15
JUCT263P-A-T4B	2	2.0	2.25	15	JUCT263P-A-T5B	2	1.6	1.8	15
JUCT374P-A-T4B	3	3.0	3.25	15	JUCT374P-A-T5B	3	2.4	2.6	15
JUCT383P-A-T4B	3	3.0	3.25	15	JUCT383P-A-T5B	3	2.4	2.6	15
JUCT393P-A-T4B	3	3.0	3.25	15	JUCT393P-A-T5B	3	2.4	2.6	15

All fan motors are 3/4 H.P.

# JUCT MEDIUM PROFILE SPECIFICATIONS

## CAPACITY DATA - 50HZ (BTUH)

High Temp Model	JUCT	120A	125A	131A	239A	247A	254A	263A	374A	383A	393A
Capacity 1°F T. D.	BTUH	1,840	2,300	2,852	3,588	4,324	4,968	5,796	6,808	7,636	8,556
Capacity 10 °F T. D.	BTUH	18,400	23,000	28,520	35,880	43,240	49,680	57,960	68,080	76,360	85,560
Capacity 1 °F T. D.	BTUH	27,600	34,500	42,780	53,820	64,860	74,520	86,940	102,120	114,540	128,340
CFM	cfm	2,490	3,901	3,777	7,802	7,802	7,553	7,553	11,330	11,330	10,915
Refrigerant Charge*	Lbs.	3.4	6.1	9	8.9	11.8	14.9	17.9	17.7	23	26.5
Approx. Shipping Wt.	Lbs.	160	190	205	350	370	380	390	540	560	580

\* R22 at +20°F S.S.T. with coil 30% full

## ELECTRICAL DATA - FAN MOTORS 50HZ

200-220/1/50					200-220/3/50				
MODEL	FAN MOTOR QTY	FAN FLA TOTAL	MIN. CIRC. AMPACITY (A)	MAX. FUSE (AMPS)	MODEL	FAN MOTOR QTY	FAN FLA TOTAL	MIN. CIRC. AMPACITY (A)	MAX. FUSE (AMPS)
JUCT120P-A-S6B	1	3.1	3.88	15	JUCT120P-A-T7B	1	1.7	2.13	15
JUCT125P-A-S6B	1	3.1	3.88	15	JUCT125P-A-T7B	1	1.7	2.13	15
JUCT131P-A-S6B	1	3.1	3.88	15	JUCT131P-A-T7B	1	1.7	2.13	15
JUCT239P-A-S6B	2	6.2	6.98	15	JUCT239P-A-T7B	2	3.4	3.83	15
JUCT247P-A-S6B	2	6.2	6.98	15	JUCT247P-A-T7B	2	3.4	3.83	15
JUCT254P-A-S6B	2	6.2	6.98	15	JUCT254P-A-T7B	2	3.4	3.83	15
JUCT263P-A-S6B	2	6.2	6.98	15	JUCT263P-A-T7B	2	3.4	3.83	15
JUCT374P-A-S6B	3	9.3	10.08	15	JUCT374P-A-T7B	3	5.1	5.53	15
JUCT383P-A-S6B	3	9.3	10.08	15	JUCT383P-A-T7B	3	5.1	5.53	15
JUCT393P-A-S6B	3	9.3	10.08	15	JUCT393P-A-T7B	3	5.1	5.53	15

380-400/3/50				
MODEL	FAN MOTOR QTY	FAN FLA TOTAL	MIN. CIRC. AMPACITY (A)	MAX. FUSE (AMPS)
JUCT120P-A-T9B	1	0.8	1.0	15
JUCT125P-A-T9B	1	0.8	1.0	15
JUCT131P-A-T9B	1	0.8	1.0	15
JUCT239P-A-T9B	2	1.6	1.8	15
JUCT247P-A-T9B	2	1.6	1.8	15
JUCT254P-A-T9B	2	1.6	1.8	15
JUCT263P-A-T9B	2	1.6	1.8	15
JUCT374P-A-T9B	3	2.4	2.6	15
JUCT383P-A-T9B	3	2.4	2.6	15
JUCT393P-A-T9B	3	2.4	2.6	15

All fan motors are 3/4 H.P.

# JUCT MEDIUM PROFILE WIRING DIAGRAM

## UNIT COOLER WIRING DIAGRAM - AIR DEFROST

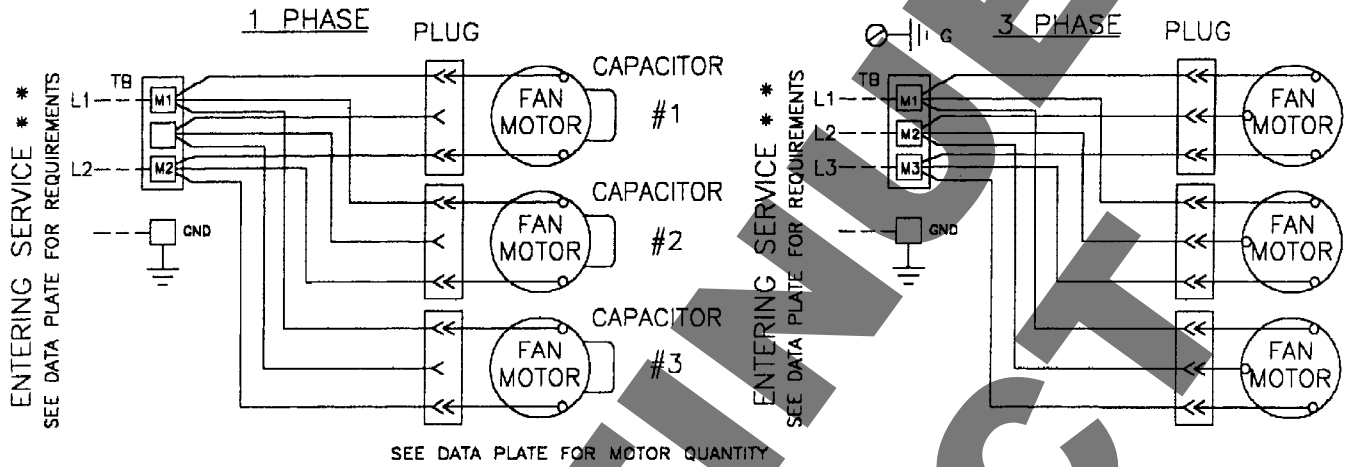

### TYPICAL FIELD WIRING \*\* WITHOUT TIME CLOCK (OFF CYCLE AIR DEFROST)

### TYPICAL FIELD WIRING \*\* WITH TIME CLOCK (AIR DEFROST)

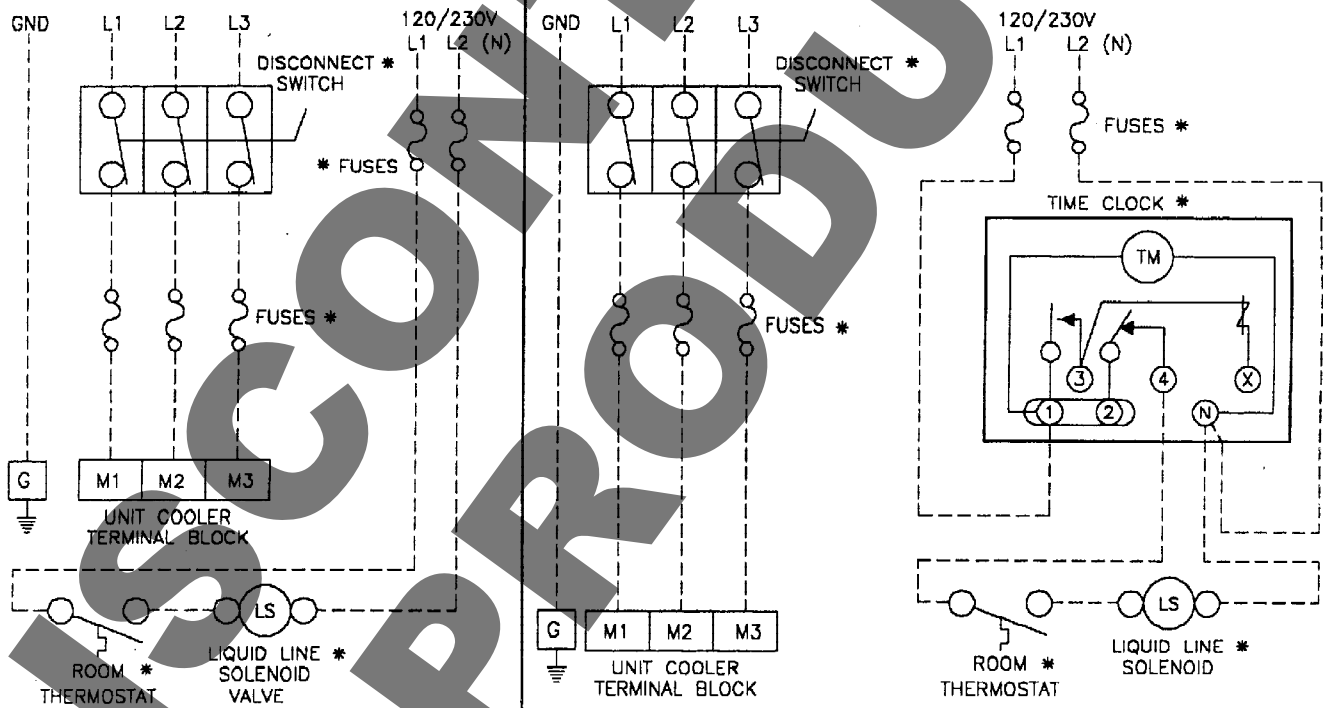

#### NOTES

- \* COMPONENTS BY OTHERS
- FACTORY WIRING
- - - WIRING BY OTHERS

\*\* ALL FIELD WIRING TO BE IN COMPLIANCE WITH ALL APPLICABLE LOCAL AND NATIONAL CODES.

1045139-B

# JUCT MEDIUM PROFILE DIMENSIONAL DATA

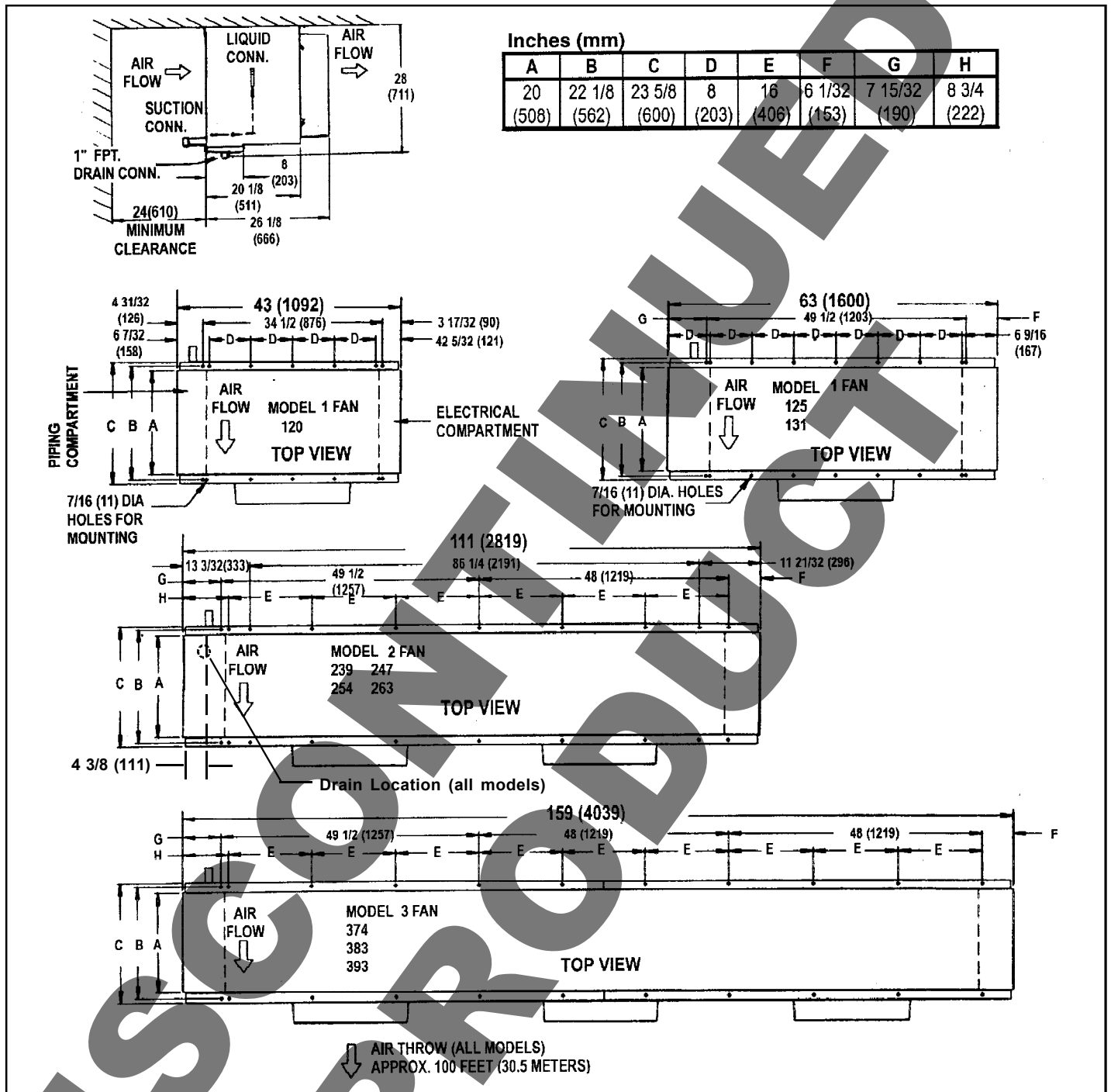

## DIMENSIONAL DATA

INCHES (MILLIMETRES)

High Temp Air Defrost Model	120	125	131	239	247	254	263	374	383	393
Number of Fans	1	1	1	2	2	2	2	3	3	3
Liquid Connection (O.D. Sweat)	5/8 (16)	5/8 (16)	5/8 (16)	5/8 (16)	7/8 (22)	7/8 (22)	7/8 (22)	7/8 (22)	7/8 (22)	7/8 (22)
Suction Connection (O.D. Sweat)	7/8 (22)	1 1/8 (29)	1 1/8 (29)	1 3/8 (35)	1 3/8 (35)	1 5/8 (41)	1 5/8 (41)	1 5/8 (41)	1 5/8 (41)	2 1/8 (54)

# JUCT MEDIUM PROFILE

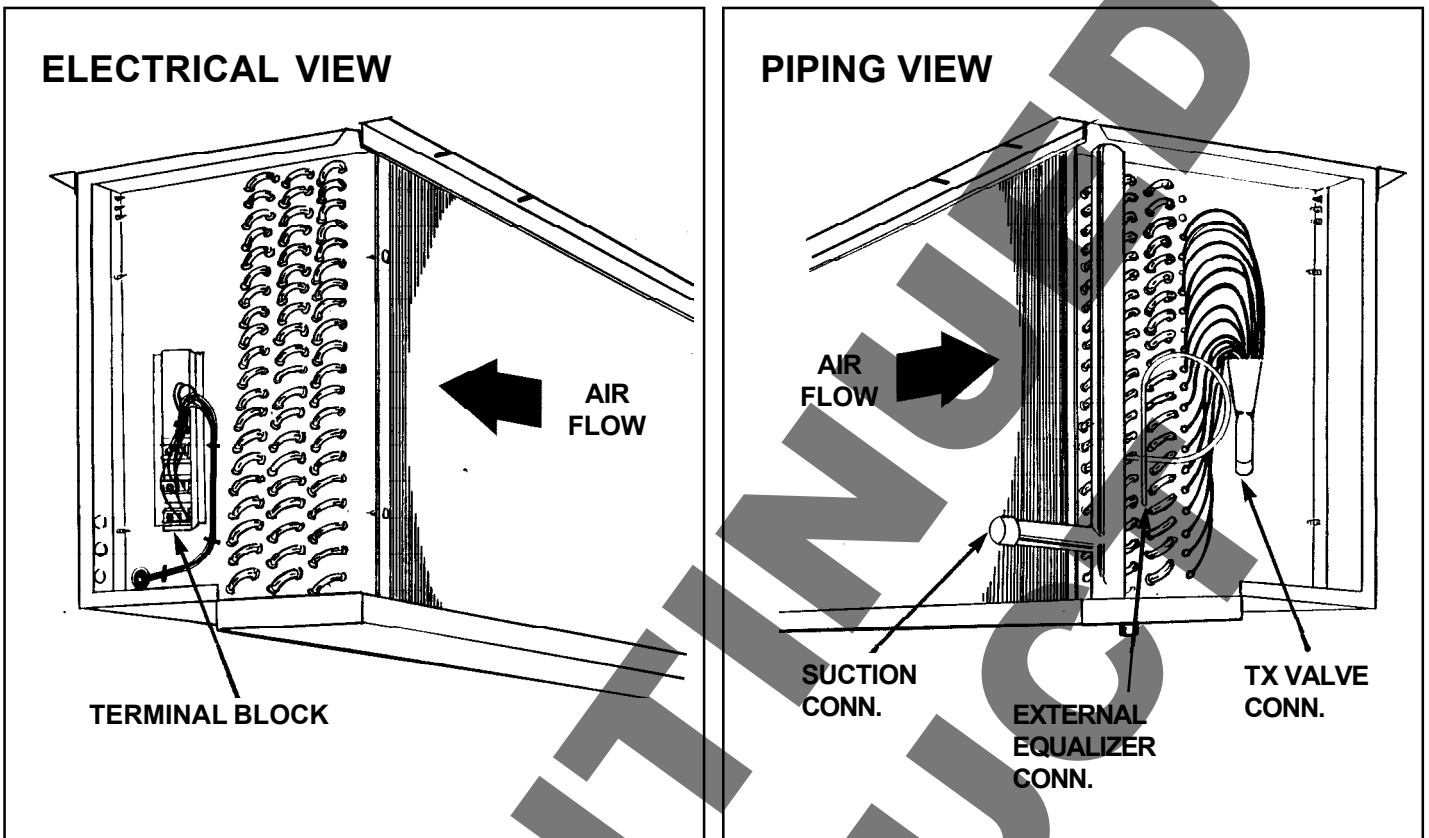

## THERMOSTATIC EXPANSION VALVE SELECTION CHART FOR +35 °F ROOMS AND UP

MODEL	T.D.	CAPACITY MBH	ALCO VALVE MODEL*			SPORLAN VALVE MODEL		
			REFRIGERANT R22	REFRIGERANT R502/404A/507	REFRIGERANT R134a	REFRIGERANT R22	REFRIGERANT R502/404A/507	REFRIGERANT R12/R134a
120A	10	20	HFES-2-HC	HFES-1 1/2-RC	HFES-1 1/2-MC	EGVE-1 1/2-C	EGSE-1 1/2-C	EGJE-1 1/2-C
	15	30	HFES-2 1/2-HC	HFES-2-RC	HFES-2 1/2-MC	EGVE-3-C	EGSE-2-C	EGJE-2-C
125A	10	25	HFES-2-HC	HFES-2-RC	HFES-1 3/4-MC	EGVE-2-C	EGSE-2-C	EGJE-1 1/2-C
	15	37.5	HFES-3-HC	HFES-3 1/2-RC	HFES-4-MC	EGVE-3-C	SSE-3-C	SJE-2 1/2-C
131A	10	31	HFES-2 1/2-HC	HFES-3 1/2-RC	HFES-2 1/2-MC	EGVE-3-C	EGSE-2-C	EGJE-2-C
	15	46.5	HFES-5 1/2-HC	HFES-3 1/2-RC	HFES-4-MC	EGVE-3-C	SSE-4-C	SJE-3-C
239A	10	39	HFES-3-HC	HFES-3 1/2-RC	HFES-4-MC	EGVE-3-C	SSE-3-C	SJE-2 1/2-C
	15	58.5	HFES-5 1/2-HC	HFES-5-RC	HFES-4-MC	SVE-4-C	SSE-4-C	SJE-5-C
247A	10	47	HFES-5 1/2-HC	HFES-3 1/2-RC	HFES-4-MC	EGVE-3-C	SSE-4-C	SJE-3-C
	15	70.5	HFES-5 1/2-HC	HFES-5-RC	HFES-6-MC	SVE-5-C	SSE-6-C	SJE-6-C
254A	10	54	HFES-5 1/2-HC	HFES-5-RC	HFES-4-MC	SVE-4-C	SSE-4-C	SJE-5-C
	15	81	HFES-8-HC	HFES-7-RC	HFES-6-MC	SVE-8-C	SSE-7-C	SJE-6-C
263A	10	63	HFES-5 1/2-HC	HFES-5-RC	HFES-4-MC	SVE-4-C	SSE-4-C	SJE-5-C
	15	94.5	HFES-8-HC	HFES-10-RC	HFES-7 1/2-MC	SVE-8-C	SSE-7-C	OJE-6-C
374A	10	74	HFES-5 1/2-HC	HFES-7-RC	HFES-6-MC	SVE-5-C	SSE-6-C	OJE-9-C
	15	111	HFES-10-HC	HFES-10-RC	HFES-7 1/2-MC	SVE-8-C	OSE-9-C	OJE-12-C
383A	10	83	HFES-8-HC	HFES-7-RC	HFES-6-MC	SVE-8-C	SSE-7-C	SJE-6-C
	15	124.5	HFES-10-HC	HFES-10-RC	HFES-11-MC	SVE-10-C	OSE-9-C	OJE-9-C
393A	10	93	HFES-8-HC	HFES-10-RC	HFES-7 1/2-MC	SVE-8-C	OSE-7-C	OJE-6-C
	15	139.5	HFES-10-HC	TRAE-12-RC	HFES-11-MC	SVE-10-C	OSE-12-C	OJE-9-C

\* Where available use the HFESC series valve which includes sweat fittings with a removable/cleanable inlet screen.

Note: Above Selections are based on 100°F Entering Liquid Temperature.

VENTURI - FLO distributor does not require the selection or use of distributor nozzles.

# JUCT MEDIUM PROFILE

## APPLICATION

High Temp Unit Coolers are designed for use with R12, R22, R134a, R404A, R407A/B/C, R507 or R502 refrigerants.

At room temperatures above 34°F and evaporating temps no lower than 27°F the air flowing through the coil will accomplish the defrost. Temperatures of 34°F and below (to -40°F) require positive defrosting. (either Electric or Hot Gas).

The coil must not be exposed to any abnormal atmospheric or acidic environments. This may result in corrosion to the cabinet and possible coil failure (leaks). (Consult manufacturer for optional baked on phenolic protective coatings).

## INSTALLATION

The installation and start-up of Unit Coolers should only be performed by qualified refrigeration mechanics.

This equipment should be installed in accordance with all applicable codes, ordinances and local by-laws.

## INSPECTION

Inspect all equipment before unpacking for visible signs of damage or loss. Check shipping list against material received to ensure shipment is complete.

**IMPORTANT:** Remember, you, the consignee, must make any claim necessary against the transportation company.

Shipping damage or missing parts, when discovered at the outset, will prevent later unnecessary and costly delays.

**If damage or loss during transport is evident, make claim to carrier, as this will be their responsibility, not the manufacturer's.**

Should carton be damaged, but damage to equipment is not obvious, a claim should be filed for "concealed damage" with the carrier.

**IMPORTANT:** The electrical characteristics of the unit should be checked at this time to make sure they correspond to those ordered and to electrical power available at the job site.

Save all shipping papers, tags and instruction sheets for reference by installer and owner.

## LOCATION

The unit location in the room should be selected to ensure uniform air distribution throughout the entire space to be refrigerated. Be sure that the unit does not draw air in, or blow directly out, through an opened door and that the product does not obstruct the free circulation of air. Allow a minimum of 24" clearance at each end and behind the unit.

The Unit Coolers draw air through the coil and discharge air from the fan side.

Consideration should be given to the coil location in order to minimize the piping run length to the condensing unit and floor drain.

## MOUNTING

Mounting brackets with 7/16" dia holes are provided for flush mounting to the ceiling. For details refer to dimensional data on page 5. Ensure adequate clearance (at least 24") is provided behind the coil as well as each side (to enable access to the electrical and refig. compartments).

**Ensure that the ceiling is level since the drain pan has been sloped for drainage during the defrost cycle.**

## DRAIN LINE

The drain line should be run from the drain connection, sloping at least 4" per foot. A trap outside the room will prevent warm air from entering through the tubing. Connection should be made to proper drainage facilities that comply with local regulations.

The drain pan may be reversed to provide a drain connection at either end.

**Ensure that the drain pan has sufficient slope for proper drainage (prevention of ice build up/blockage in pan).**

## PIPING

Refrigerant line sizes are important and may not be the same size as the coil connections. (depends on the length of run) If in doubt, consult "Recommended refrigerant line sizes" charts. (Engineering Manuals or other recognized sources of information).

## WIRING

Wire system in accordance with governing standards and local codes. See data and wiring diagrams on pages 2, 3 and 4 for wiring arrangement. Electrical wiring is to be sized in accordance with minimum ampacity rating.

## SYSTEM CHECK

### Before Start-Up:

1. All wiring should be in accordance with local codes.
2. Refrigerant lines should be properly sized.
3. Off-cycle defrost systems should include a liquid line solenoid valve.
4. Thorough evacuation and, dehydration has been performed.
5. The suction, discharge, and receiver service valves must be open.
6. The system should include a liquid line drier moisture indicator and suction filter.
7. Pour enough water into the drain pan to allow a good check on drainage and seal the trap.

### After Start-Up:

1. Check the compressor oil level to ensure the correct oil charge.
2. Be sure that the expansion valve is properly set to provide the correct amount of superheat.
3. Heavy moisture loads are usually encountered when starting the system for the first time.
4. Check for proper evaporator fan blade rotation.

## MAINTENANCE

The unit should be periodically inspected for any dirt or build-up on the fin surface and cleaned if necessary with a soft whisk or brush.

# JUCT MEDIUM PROFILE SERVICE PARTS

<b>FAN MOTORS - 60HZ</b> 208-230/1/60 208-230/3/60 460/3/60 575/3/60	<b>MODELS</b> ALL ALL ALL ALL	<b>PART #</b> 1045032 1045033 1045034 1045035
<b>FAN MOTORS - 50HZ</b> 200-220/1/50 200-220/3/50 380-400/3/50	<b>MODELS</b> ALL ALL ALL	<b>PART #</b> 1045032 1045033 1045034
<b>FAN BLADES</b> 20" 18° Pitch 4-Blade 20" 23° Pitch 4-Blade	<b>MODELS</b> 120A ALL (EXCEPT 120A)	<b>PART #</b> 1048568 1045115
<b>FAN GUARDS</b> Moulded Throw Booster (standard) Metal Wire (optional) Acorn Nut	<b>MODELS</b> ALL ALL ALL	<b>PART #</b> 1045089 1045091 1045138
<b>MOTOR MOUNT</b>	ALL	1045031
<b>TERMINAL BLOCK</b>	ALL	1045017

## SERVICE LOG

DATE	COMMENTS

## PROJECT INFORMATION

System	
Model Number	Date of Start-Up
Serial Number	Service Contractor
Refrigerant	Phone
Electrical Supply	Fax



TM

**NATIONAL REFRIGERATION & AIR CONDITIONING CANADA CORP.**  
159 Roy Blvd. • Brantford • Ontario, Canada N3R 7K1  
Phone (519) 751-0444 • 800-463-9517 • Fax: (519) 753-1140



ANSI/NSF 7  
1R71

Due to National Refrigeration's policy of continuous product improvement, we reserve the right to make changes without notice.