



60
Hz

MULTI-COMPRESSOR CONDENSING UNITS

PRODUCT DATA & SPECIFICATIONS

INDOOR/OUTDOOR
MULTIPLE COMPRESSOR
AIR COOLED CONDENSING UNITS

1/2 TO 6.0 HP HERMETIC
SCROLL & SEMI-PHERMETIC
COMPRESSOR (MAX. 18HP TOTAL)

Bulletin T40-TF-PDS-60-1

1081581

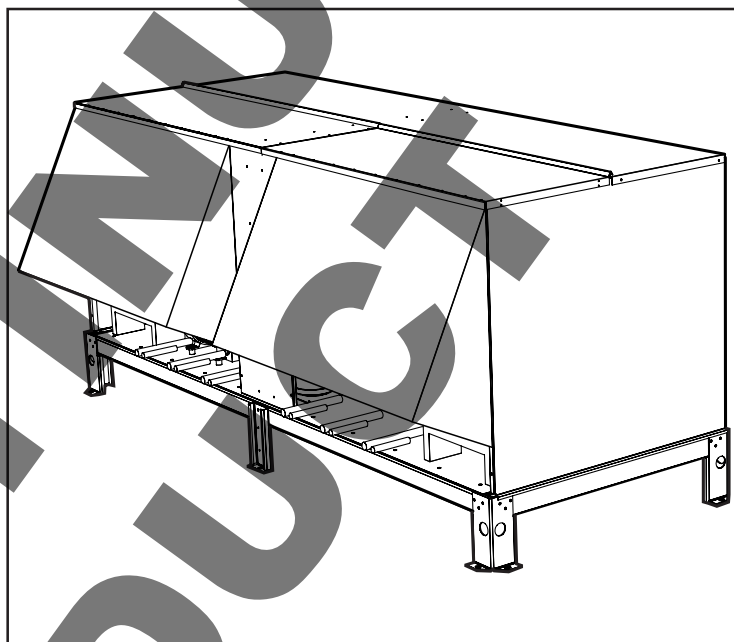

CONTENTS

	Page
Nomenclature.....	2
Selection Process.....	2
Features.....	3
Compressor Selections.....	4-7
Electrical Data.....	8-11
Dimensional Data.....	12
Wiring Diagrams.....	13-14

NOMENCLATURE

TF H T 180 H 6 - H T3 X

TF = Model Series

Compressor Type

H = Hermetic compressor
 Z = Scroll Compressor
 S = Semi-hermetic Compressor
 M = Mixture of above

Cabinet Size

S = Single fan Section - maximum 6 HP
 D = Double fan Section - maximum 12 HP
 T = Triple fan section - maximum 18 HP

Nominal HP

180 = 18 HP

Application Range

H = High and Med Temp (0 to 45°F evap temp)
 M = Med Temp (0 to 30 °F evap temp)
 L = Low Temp (-40 to 0 °F evap temp)
 E = Extended Medium Temp (-20 to 30 °F evap temp)
 C = Combination of any of the above

* Subject to compressor availability

Series / Generation

X = Special Custom model

Voltage *

S2 = 208/230/1/60 *
 S3 = 230/1/60 *
 S6 = 200-220/1/50 *
 S7 = 200/1/50*
 T3 = 208-230/3/60
 T4 = 460/3/60
 T5 = 575/3/60
 T7 = 200-220/3/50
 T9 = 380-400/3/50

* subject to compressor availability

Enclosure

H = Outdoor
 I = Indoor

Refrigerant

2 = R22 , 6 = R404A / R507 ,
 9 = Mixed appl. R22 and R404A / R507

SELECTION PROCESS

1) Select Compressor Models:

Select your compressor models (Capacity and HP) using the compressor specifications on pages 4 thru 7. This can be a combination of:

- any refrigerant (R22 or R404A)
 - any application (High, Medium or Low Temperature)
 - any type of compressor (Hermetic, Scroll or Semi-Hermetic)
- If a compressor has a nominal rating with a + or ++ after the HP number, increase the HP rating by an extra ½ HP.

2) Select the Cabinet:

Select the cabinet using the following guidelines:

- Maximum 6 HP per fan section.
- Maximum 3 compressors per fan section. Based on 95° F (35° C) design ambient. If semi-hermetic compressors are selected, only one optional suction accumulator per fan section can be used.
- Maximum 3 fan sections.

3) Select the Unit Model Number:

Refer to the nomenclature chart above.

Consult factory for any special requirements.

STANDARD FEATURES

- Total system flexibility using multiple compressor models and applications on a common chassis.
- Up to **Three fan** section cabinet choices of either Hermetic, Scroll or Semi-Hermetic multiple compressors with maximum **Three compressors per fan** section.
- Compressor sizes available ranging from 1/2 through 6 HP, to a maximum total of **6HP per fan section** and 18 HP per unit. (Based on 95 °F (35 °C) design Ambient).
- Semi-hermetic (2 HP and larger) use suction and discharge vibration eliminators and spring mounts.
- High efficiency enhanced tube on both indoor or outdoor condenser design using high efficiency PSC fan motors.
- Outdoor unit uses weather-resistant housing with hinged hood, weatherproof electrical panel and fixed head pressure flooding valve.
- Each compressor includes main power fuse block, contactor, adjustable Dual (low /high) pressure control, oil pressure control (where applicable) and fused control circuit.
- Single Point Main electrical panel with defrost timeclock and contactor options available for air and electric defrost evaporators. (single point dependant on evaporator voltage).
- Includes liquid line drier and sightglass.

OPTIONAL COMPONENTS (Factory mounted)

- Sealed Suction Filter
- Suction accumulator*
- Discharge line check valve
- Receiver Inlet ball valve
- Heated and insulated receiver
- Flex hoses -for pressure controls
- Field piping connections at rear (instead at front)
- Main disconnect switch
- Main disconnect fusing
- Voltage /Phase monitor
- Compressor circuit breaker
- Compressor anti short cycle time delay relay
- Current sensing relay -for use with Oil control (where applicable)
- Sentronic Oil pressure control (where applicable)
- OMB Oil level Control (where applicable)
- Air or Electric Defrost Kit
- Pumpdown toggle switch
- Liquid Line solenoid valve-with standard 230V coil (shipped loose)
- Spare condenser circuit for remote ice machine

* for semi-hermetic compressors - maximum one suction accumulator per fan section.

OTHER OPTIONS AVAILABLE UPON REQUEST.
CONSULT FACTORY FOR DETAILS



HERMETIC COMPRESSOR SELECTIONS

60Hz

H2 - High/Medium Temperature - R22

NOMINAL COMPRESSOR HP	COPELAND MODEL	NOMINAL CAPACITY - BTU/H (WATTS) *		FIELD CONNECTIONS		RECEIVER (90% Lbs)	
		25 °F (-3.9 °C)	40 °F (7.2 °C)	SUCTION	LIQUID	STANDARD	OVERSIZE
1/2	ART82-C1	5970 (1749)	8300 (2431)	1/2	3/8	6	12.5
3/4	RS64C2	8090 (2370)	10800 (3163)	5/8	3/8	6	12.5
1	RS70C1	8870 (2598)	12200 (3573)	5/8	3/8	6	12.5
1 1/2	CR18KQ	13000 (3808)	18600 (5448)	5/8	3/8	12.5	16
2	CR24KQ	16100 (4716)	22300 (6532)	5/8	3/8	12.5	16
2 1/2	CR32KQ	21800 (6385)	29400 (8611)	7/8	3/8	16	34.5
3	CR37KQ	26600 (7791)	36400 (10662)	7/8	1/2	24.7	34.5
3 1/2	CR41KQ	29300 (8582)	40100 (11745)	7/8	1/2	24.7	34.5
4	CR53KQ	36200 (10603)	49000 (14352)	1 1/8	1/2	24.7	34.5
5	CRN5-0500	43900 (12858)	59000 (17281)	1 1/8	1/2	24.7	34.5

E6 - Extended Medium Temperature - R404A

NOMINAL COMPRESSOR HP	COPELAND MODEL	NOMINAL CAPACITY - BTU/H (WATTS) *		FIELD CONNECTIONS		RECEIVER (90% Lbs)	
		-10 °F (-23.3 °C)	25 °F (-3.9 °C)	SUCTION	LIQUID	STANDARD	OVERSIZE
1/2	RS43C2E	2580 (756)	6330 (1854)	5/8	3/8	5.4	11.3
3/4	RS55C2E	3190 (934)	7840 (2296)	5/8	3/8	5.4	11.3
3/4 +	RS64C2E	3820 (1119)	8660 (2537)	5/8	3/8	5.4	11.3
1	RS70C1E	4010 (1175)	9490 (2780)	5/8	3/8	5.4	11.3
1 1/2	CS10K6E	5350 (1567)	15200 (4452)	5/8	3/8	11.3	14.4
2	CS12K6E	6310 (1848)	17400 (5096)	5/8	3/8	11.3	14.4
2 1/2	CS14K6E	8070 (2364)	20300 (5946)	7/8	1/2	14.4	21.5
3	CS18K6E	10160 (2976)	27700 (8113)	7/8	1/2	21.5	31
3 1/2	CS20K6E	11680 (3421)	30800 (9021)	7/8	1/2	21.5	31
4	CS27K6E	14900 (4364)	37900 (11101)	7/8	1/2	21.5	31
5	CS33K6E	18100 (5301)	43700 (12800)	7/8	1/2	21.5	31

L6 - Low Temperature - R404A

NOMINAL COMPRESSOR HP	COPELAND MODEL	NOMINAL CAPACITY - BTU/H (WATTS) *		FIELD CONNECTIONS		RECEIVER (90% Lbs)	
		-20 °F (-28.9 °C)	-10 °F (-23.3 °C)	SUCTION	LIQUID	STANDARD	OVERSIZE
1/2	AFT22C1E	2090 (612)	2730 (800)	1/2	3/8	5.4	11.3
3/4	AFT26C1E	2550 (747)	3380 (990)	1/2	3/8	5.4	11.3
1	CF04K6E	3710 (1087)	5150 (1508)	5/8	3/8	5.4	11.3
2	CF06K6E	5910 (1731)	8100 (2372)	7/8	3/8	11.3	14.4
2 1/2	CF09K6E	9100 (2665)	12500 (3661)	7/8	3/8	11.3	14.4
3	CF12K6E	11600 (3398)	15200 (4452)	7/8	1/2	14.4	21.5

* At 95 °F (35 °C) Ambient
Refer to Bulletin T40-TEH-PDS-60 for further capacity data.



SCROLL COMPRESSOR SELECTIONS

60Hz

H2 - High/Medium Temperature - R22

NOMINAL COMPRESSOR HP	COPELAND MODEL	NOMINAL CAPACITY - BTU/H (WATTS) *		FIELD CONNECTIONS		RECEIVER (90% Lbs)	
		25 °F (-3.9 °C)	40 °F (7.2 °C)	SUCTION	LIQUID	STANDARD	OVERSIZE
2	ZB15KCE	18200 (5331)	23800 (6971)	7/8	3/8	13	16
2 1/2	ZB19KCE	20700 (6063)	27200 (7967)	7/8	3/8	16	24.7
3	ZB21KCE	27400 (8025)	36200 (10603)	1 1/8	1/2	24.7	34.5
3 1/2	ZB26KC	31300 (9168)	41000 (12009)	1 1/8	1/2	24.7	34.5
4	ZB30KCE	36000 (10544)	47100 (13796)	1 1/8	1/2	24.7	34.5
5	ZB38KCE	44400 (13005)	58200 (17047)	1 1/8	1/2	24.7	34.5
6	ZB45KCE	53900 (15787)	71000 (20796)	1 3/8	5/8	34.5	50

M6 - Medium Temperature - R404A

NOMINAL COMPRESSOR HP	COPELAND MODEL	NOMINAL CAPACITY - BTU/H (WATTS) *		FIELD CONNECTIONS		RECEIVER (90% Lbs)	
		5 °F (-15 °C)	25 °F (-3.9 °C)	SUCTION	LIQUID	STANDARD	OVERSIZE
1 1/2	ZB10KCE	8340 (2443)	12200 (3573)	5/8	3/8	11.3	14.4
1 3/4	ZB11KCE	9150 (2680)	13400 (3925)	7/8	3/8	11.3	14.4
2	ZB13KCE	10900 (3193)	16300 (4774)	7/8	3/8	11.3	14.4
2+	ZB15KCE	12600 (3691)	18200 (5331)	7/8	3/8	11.3	14.4
2 1/2	ZB19KCE	15700 (4599)	24600 (7205)	7/8	1/2	14.4	21.5
3	ZB21KCE	19500 (5712)	28400 (8318)	1 1/8	1/2	21.5	31
3 1/2	ZB26KCE	22400 (6561)	35300 (10339)	1 1/8	1/2	21.5	31
4	ZB30KCE	24800 (7264)	39500 (11570)	1 1/8	1/2	21.5	31
5	ZB38KCE	31500 (9226)	49300 (14440)	1 1/8	1/2	21.5	31
6	ZB45KCE	38100 (11159)	60100 (17603)	1 3/8	5/8	31	44

L6 - Low Temperature - R404A

NOMINAL COMPRESSOR HP	COPELAND MODEL	NOMINAL CAPACITY - BTU/H (WATTS) *		FIELD CONNECTIONS		RECEIVER (90% Lbs)	
		-20 °F (-28.9 °C)	-10 °F (-23.3 °C)	SUCTION	LIQUID	STANDARD	OVERSIZE
2	ZF06K4E	7800 (2285)	9600 (2812)	7/8	3/8	11.3	14.4
2 1/2	ZF08K4E	9900 (2900)	12200 (3573)	7/8	3/8	14.4	21.5
3	ZF09K4E	11000 (3222)	13500 (3954)	7/8	3/8	14.4	21.5
3 1/2	ZF11K4E	13300 (3896)	16300 (4774)	1 1/8	1/2	14.4	21.5
4 1/2	ZF13K4E	15400 (4511)	19200 (5624)	1 1/8	1/2	21.5	31
5 1/2	ZF15K4E	18800 (5507)	23100 (6766)	1 1/8	1/2	21.5	31
6	ZF18K4E	22800 (6678)	28000 (8201)	1 3/8	1/2	31	44

* At 95 °F (35 °C) Ambient
Refer to Bulletin T40-TEZ-PDS-60 for further capacity data.

H2 - High/Medium Temperature - R22

NOMINAL COMPRESSOR HP	COPELAND MODEL	NOMINAL CAPACITY - BTU/H (WATTS) *		FIELD CONNECTIONS		RECEIVER (90% Lbs)	
		25 °F (-3.9 °C)	40 °F (7.2 °C)	SUCTION	LIQUID	STANDARD	OVERSIZE
1/2	HAG-0050	4390 (1286)	6090 (1784)	1/2	3/8	6	12.5
3/4	KAN-0075	6920 (2027)	9420 (2759)	1/2	3/8	6	12.5
1	KAR-0100	9530 (2791)	12800 (3749)	5/8	3/8	6	12.5
1 1/2	KAG-0150	12000 (3515)	16500 (4833)	7/8	3/8	16	24.7
2	KAK-0200	16600 (4862)	22400 (6561)	7/8	1/2	16	24.7
3	ERF-0310	27110 (7941)	36650 (10735)	1 1/8	1/2	24.7	34.5
4	NRB-0400	37110 (10870)	50900 (14909)	1 1/8	1/2	24.7	34.5
5	2DC3-0500	44280 (12970)	60330 (17671)	1 3/8	5/8	34.5	50
5+	2DD3-0500	50650 (14835)	68350 (20020)	1 3/8	5/8	34.5	50

M2 - Medium Temperature - R22

NOMINAL COMPRESSOR HP	COPELAND MODEL	NOMINAL CAPACITY - BTU/H (WATTS) *		FIELD CONNECTIONS		RECEIVER (90% Lbs)	
		15 °F (-9.4 °C)	25 °F (-3.9 °C)	SUCTION	LIQUID	STANDARD	OVERSIZE
1/2	HAI-0050	3890 (1139)	4880 (1429)	1/2	3/8	6	12.5
3/4	KAE-0075	6050 (1772)	7560 (2214)	5/8	3/8	6	12.5
1	KAM-0100	8450 (2475)	10600 (3105)	5/8	3/8	6	12.5
2	ERC-0200	14300 (4188)	18300 (5360)	7/8	1/2	16	24.7
3	3RA-0310	25150 (7366)	30990 (9077)	1 1/8	1/2	24.7	34.5
5	NRM-0500	42280 (12384)	52400 (15348)	1 1/8	1/2	34.5	50

M6 - Medium Temperature - R404A

NOMINAL COMPRESSOR HP	COPELAND MODEL	NOMINAL CAPACITY - BTU/H (WATTS) *		FIELD CONNECTIONS		RECEIVER (90% Lbs)	
		5 °F (-15 °C)	25 °F (-3.9 °C)	SUCTION	LIQUID	STANDARD	OVERSIZE
1/2	HAI-005E	3250 (952)	5040 (1476)	1/2	3/8	5.2	11.3
3/4	KAN-007E	4100 (1201)	6550 (1918)	1/2	3/8	5.2	11.3
1	KAR-010E	6300 (1845)	9360 (2742)	5/8	3/8	5.2	11.3
1 1/2	KAG-010E	7800 (2285)	11200 (3280)	5/8	3/8	11.3	14.4
2	KAK-020E	10200 (2988)	15400 (4511)	7/8	1/2	14.4	21.5
2+	ERC-021E	12700 (3720)	19400 (5682)	7/8	1/2	14.4	21.5
3	ERF-031E	18700 (5477)	28360 (8307)	7/8	1/2	21.5	31
3 1/2	3RA-031E	22100 (6473)	34730 (10172)	1 1/8	5/8	21.5	31
4	NRB2-040E	24600 (7205)	38350 (11233)	1 1/8	5/8	21.5	31
5	2DC3-050E	29110 (8526)	45240 (13251)	1 1/8	5/8	31	44
5+	2DD3-050E	34540 (10117)	52880 (15489)	1 1/8	5/8	31	44

* At 95 °F (35 °C) Ambient
Refer to Bulletin T40-TESS-PDS-60 for further capacity data.

L6 - Low Temperature - R404A

NOMINAL COMPRESSOR HP	COPELAND MODEL	NOMINAL CAPACITY - BTU/H (WATTS) *		FIELD CONNECTIONS		RECEIVER (90% Lbs)	
		-20 °F (-28.9 °C)	-10 °F (-23.3 °C)	SUCTION	LIQUID	STANDARD	OVERSIZE
1/2	KAN-005E	1960 (574)	2750 (805)	1/2	3/8	5.2	11.3
3/4	KAM-007E	3440 (1008)	4580 (1341)	5/8	3/8	5.2	11.3
1	KAJ-010E	4460 (1306)	5760 (1687)	7/8	3/8	5.2	11.3
1 1/2	KAL-015E	6910 (2024)	8960 (2624)	7/8	3/8	14.4	21.5
2	EAD-020E	7590 (2223)	10100 (2958)	7/8	3/8	14.4	21.5
2+	EAV-020E	8770 (2569)	11400 (3339)	7/8	1/2	14.4	21.5
2 3/4	3AB-031E	11000 (3222)	14000 (4101)	7/8	1/2	21.5	31
3	LAH-031E	13920 (4077)	18630 (5457)	1 1/8	1/2	21.5	31
3+	NRD-032E	16480 (4827)	21060 (6168)	1 1/8	1/2	21.5	31
3++	LAC-032E	17140 (5020)	- -	1 1/8	1/2	21.5	31
3 1/2	2DF-030E	18780 (5501)	24080 (7053)	1 1/8	1/2	21.5	31
4	2DL-040E	23110 (6769)	29510 (8643)	1 1/8	1/2	21.5	31
6	2DB-060E	28840 (8447)	36760 (10767)	1 3/8	5/8	31	44
6+	3DA-060E	31980 (9367)	40480 (11857)	1 3/8	5/8	31	44

* At 95 °F (35 °C) Ambient
Refer to Bulletin T40-TES-PDS-60 for further capacity data.

DISCONTINUED PRODUCT



ELECTRICAL DATA HERMETIC - COMPRESSOR (RLA/LRA)

60Hz

H2 - High/Medium Temperature - R22

NOMINAL COMPRESSOR HP	COMPRESSOR MODEL	208/230-1-60		208/230-3-60		460-3-60		575-3-60	
		RLA	LRA	RLA	LRA	RLA	LRA	RLA	LRA
1/2	ART82-C1	5.3	30	-	-	-	-	-	-
3/4	RS64C2	6.9	37	-	-	-	-	-	-
1	RS70C1	6.3	34.2	4.2	31	2.6	15	-	-
1 1/2	CR18KQ	8.1	41	5.4	49	3.1	23	-	-
2	CR24KQ	12.2	70.5	6.7	51	3.3	25	-	-
2 1/2	CR32KQ	15.3	83	8.8	63	4.6	32	-	-
3	CR37KQ	16.7	100	9.9	85	5	39	-	-
3 1/2	CR41KQ	17.4	109.6	11.8	80	5.3	42	-	-
4	CR53KQ	26	140	16.3	107	8.1	55	-	-
5	CRN5-0500	30.8	142	19.2	130	8.7	65	7.1	52

E6 - Extended Medium Temperature - R404A

NOMINAL COMPRESSOR HP	COMPRESSOR MODEL	208/230-1-60		208/230-3-60		460-3-60		575-3-60	
		RLA	LRA	RLA	LRA	RLA	LRA	RLA	LRA
1/2	RS43C2E	4.8	24.1	-	-	-	-	-	-
3/4	RS55C2E	5.4	40	-	-	-	-	-	-
3/4 +	RS64C2E	6.9	37	-	-	-	-	-	-
1	RS70C1E	6.3	34.2	4.2	31	2.6	15	-	-
1 1/2	CS10K6E	9.8	56	6.7	51	3.2	25	-	-
2	CS12K6E	9.8	56	6.7	51	-	-	-	-
2 1/2	CS14K6E	11.2	61	8.2	55	4.2	28	-	-
3	CS18K6E	14.4	82	7.9	65.5	4.2	33	-	-
3 1/2	CS20K6E	16.7	96	10.2	75	4.6	40	-	-
4	CS27K6E	21.5	95.4	14	82	7.6	41	-	-
5	CS33K6E	27.6	125	16.8	102	8.8	48	-	-

L6 - Low Temperature - R404A

NOMINAL COMPRESSOR HP	COMPRESSOR MODEL	208/230-1-60		208/230-3-60		460-3-60		575-3-60	
		RLA	LRA	RLA	LRA	RLA	LRA	RLA	LRA
1/2	AFT22C1E	3.3	32.5	-	-	-	-	-	-
3/4	AFT26C1E	4.1	32.2	-	-	-	-	-	-
1	CF04K6E	9.9	59.2	6.1	52	3.3	26	-	-
2	CF06K6E	10.3	59.2	6.3	52	3.7	25.4	-	-
2 1/2	CF09K6E	15	87	9.2	72.2	4.9	35.8	-	-
3	CF12K6E	18.4	105	11	85	5.9	42	-	-



ELECTRICAL DATA - SCROLL COMPRESSOR (RLA/LRA)

60Hz

H2 - High/Medium Temperature - R22 / M6 - Medium Temperature - R404A

NOMINAL COMPRESSOR HP	COMPRESSOR MODEL	208/230-1-60		208/230-3-60		460-3-60		575-3-60	
		RLA	LRA	RLA	LRA	RLA	LRA	RLA	LRA
1 1/2	ZB10KCE	10	41	-	-	-	-	-	-
1 3/4	ZB11KCE	10	45	-	-	-	-	-	-
2	ZB13KCE	12.9	54	-	-	-	-	-	-
2+	ZB15KCE	15.7	61	8.9	55	5	27	-	-
2 1/2	ZB19KCE	17.9	73	10	63	5	31	-	-
3	ZB21KCE	20.7	100	12.1	77	6.1	39	5	31
3 1/2	ZB26KC	20.7	127	13.9	88	7.1	44	5	34
4	ZB30KCE	26.8	132	15.7	115	7.5	47.5	6	38
5	ZB38KCE	31.1	175	22.1	115	9.6	63	7.7	50
6	ZB45KCE	-	-	22.5	156	11.5	70	9.2	56

L6 - Low Temperature - R404A

NOMINAL COMPRESSOR HP	COMPRESSOR MODEL	208/230-1-60		208/230-3-60		460-3-60		575-3-60	
		RLA	LRA	RLA	LRA	RLA	LRA	RLA	LRA
2	ZF06K4E	13.6	61	9.3	55	4.3	27	-	-
2 1/2	ZF08K4E	16.4	73	9.7	63	5	39	4	24
3	ZF09K4E	16.4	88	11.1	77	5.7	39	4.3	31
3 1/2	ZF11K4E	20.7	109	13.6	88	7.1	44	5	34
4 1/2	ZF13K4E	26.8	129	15	99	8.2	49.5	8.2	40
5 1/2	ZF15K4E	31.8	169	21.4	123	9.6	62	7.9	50
6	ZF18K4E	-	-	23.9	156	9.3	70	7.9	54

**ELECTRICAL DATA -
SEMI-HERMETIC COMPRESSOR
(RLA/LRA)**

H2 - High/Medium Temperature - R22

NOMINAL COMPRESSOR HP	COMPRESSOR MODEL	208/230-1-60		208/230-3-60		460-3-60		575-3-60	
		RLA	LRA	RLA	LRA	RLA	LRA	RLA	LRA
1/2	HAG-0050	4	22	2.4	13	-	-	-	-
3/4	KAN-0075	6.1	36	3.5	19.9	-	-	-	-
1	KAR-0100	7.4	40	4.3	27	2.2	13.5	-	-
1 1/2	KAG-0150	9.6	55	5.5	35.5	2.5	18.2	-	-
2	KAK-0200	10.6	55	6.8	50	3	25	-	-
3	ERF-0310	17	86	11.7	82	6.4	41	-	-
4	NRB-0400	-	-	21.8	141	11.3	62.5	-	-
5	2DC3-0500	29.9	125	22.3	120	10.4	60	7.7	49
5+	2DD3-0500	-	-	22.3	120	10.5	60	7.9	49

M2 - Medium Temperature - R22

NOMINAL COMPRESSOR HP	COMPRESSOR MODEL	208/230-1-60		208/230-3-60		460-3-60		575-3-60	
		RLA	LRA	RLA	LRA	RLA	LRA	RLA	LRA
1/2	HAI-0050	3.7	22	2.2	13	-	-	-	-
3/4	KAE-0075	5.4	36	3.4	19.9	-	-	-	-
1	KAM-0100	7.5	40	4.5	27	2.2	13.5	-	-
2	ERC-0200	10.9	58	6.8	46	3.6	23	3.2	20
3	3RA-0310	17.8	86	13.1	82	6.6	41	-	-
5	NRM-0500	-	-	24.3	141	12.1	62.5	9.2	53.4

M6 - Medium Temperature - R404A

NOMINAL COMPRESSOR HP	COMPRESSOR MODEL	208/230-1-60		208/230-3-60		460-3-60		575-3-60	
		RLA	LRA	RLA	LRA	RLA	LRA	RLA	LRA
1/2	HAI-005E	3.7	22	2.2	13	-	-	-	-
3/4	KAN-007E	5.4	36	3	19.9	-	-	-	-
1	KAR-010E	7.4	40	4.3	27	2	15	-	-
1 1/2	KAG-010E	7.5	40	4.3	27	2.2	15	-	-
2	KAK-020E	10.6	55	6.8	50	3	25	-	-
2+	ERC-021E	-	-	8.8	46	3.5	23	3.1	20
3	ERF-031E	17	86	12.4	82	5.8	41	-	-
3 1/2	3RA-031E	-	-	14.2	82	6.3	41	-	-
4	NRB2-040E	-	-	21.8	141	9	62.5	-	-
5	2DC3-050E	-	-	22.3	120	10.4	60	7.7	49
5+	2DD3-050E	-	-	22.3	120	10.5	60	7.9	49

L6 - Low Temperature - R404A

NOMINAL COMPRESSOR HP	COMPRESSOR MODEL	208/230-1-60		208/230-3-60		460-3-60		575-3-60	
		RLA	LRA	RLA	LRA	RLA	LRA	RLA	LRA
1/2	KAN-005E	3.6	24	2.2	13.2	-	-	-	-
3/4	KAM-007E	5.6	36	3.2	19.9	-	-	-	-
1	KAJ-010E	6.9	40	4.6	27	2.1	15	-	-
1 1/2	KAL-015E	9.9	55	6.6	50	3.4	25	-	-
2	EAD-020E	10	58	6.6	46	-	-	-	-
2+	EAV-020E	14.7	102	7.4	50	3.9	26.6	3.1	20
2 3/4	3AB-031E	14.7	86	10	82	5.1	41	-	-
3	LAH-031E	16.7	105	12.8	112	6	56	4.1	30
3+	NRD-032E	27.7	115	16.3	82	8.4	41	-	-
3++	LAC-032E	15.5	105	12.8	112	6	56	-	-
3 1/2	2DF-030E	25.8	125	16.8	102	8.1	52	6.7	41
4	2DL-040E	-	-	26.3	161	10.2	60	7.7	49
6	2DB-060E	-	-	28.2	161	13.3	80	9.6	63
6+	3DA-060E	-	-	30.3	150	13.7	77	10.5	62

CONDENSER FAN MOTOR (FLA) DATA (ALL MODELS)

UNIT VOLTAGE	TOTAL CONDENSER FAN FLA		
	1 FAN	2 FAN	3 FAN
208/230-1-60	2.1	4.2	6.3
208/230-3-60	2.1	4.2	6.3
460-3-60	1.1	2.2	3.3
575-3-60	0.9	1.8	2.7

DIMENSIONAL DATA

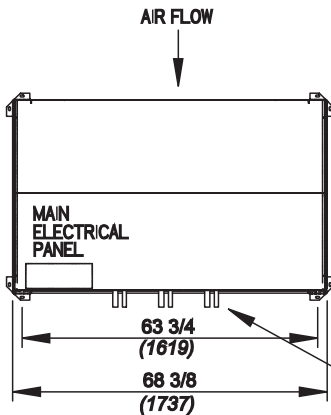

1 FAN MODEL "S"

FLIP UP HINGED FRONT COVER PANEL

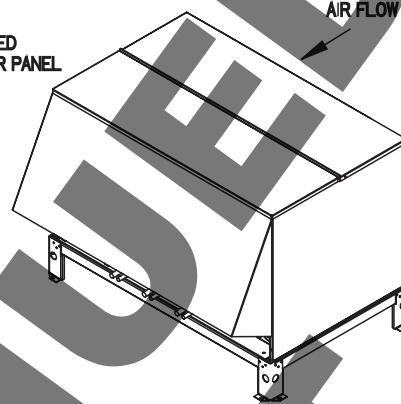

Outdoor unit shown
indoor dimensions
are minus hood

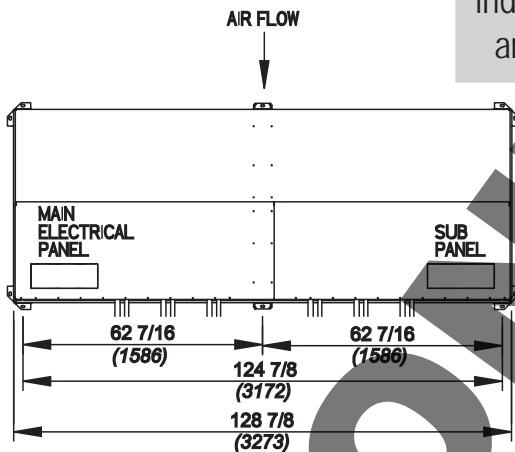

2 FAN MODEL "D"

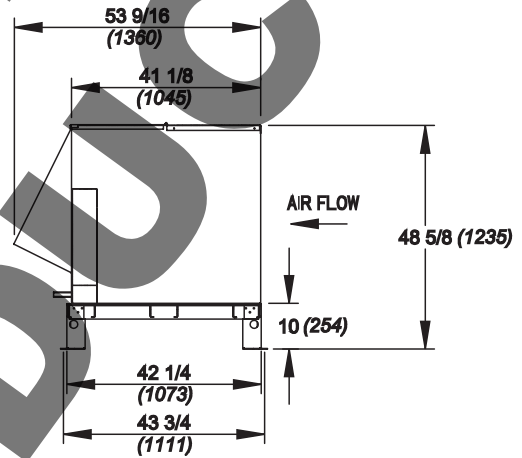

ALL MODELS

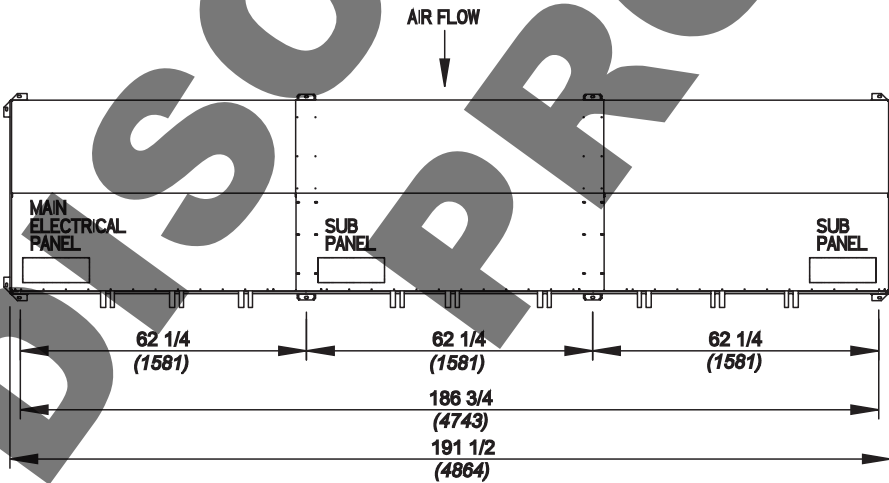

3 FAN MODEL "T"

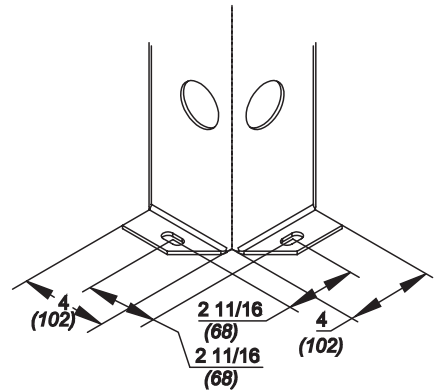

**LEG DETAIL
MTG CENTRES**

WIRING DIAGRAM

MAIN PANEL COND UNIT TYPICAL WIRING DIAGRAM
 MAIN CONTROL PANEL - COMPRESSOR / COND FAN WIRING

- 208/230V-3-60 or 200/220V-3-50 Hz
 - INHERENT LINE BREAK MOTOR PROTECTION
 - STANDARD CONTROL CIRCUIT

P.1 OF 2

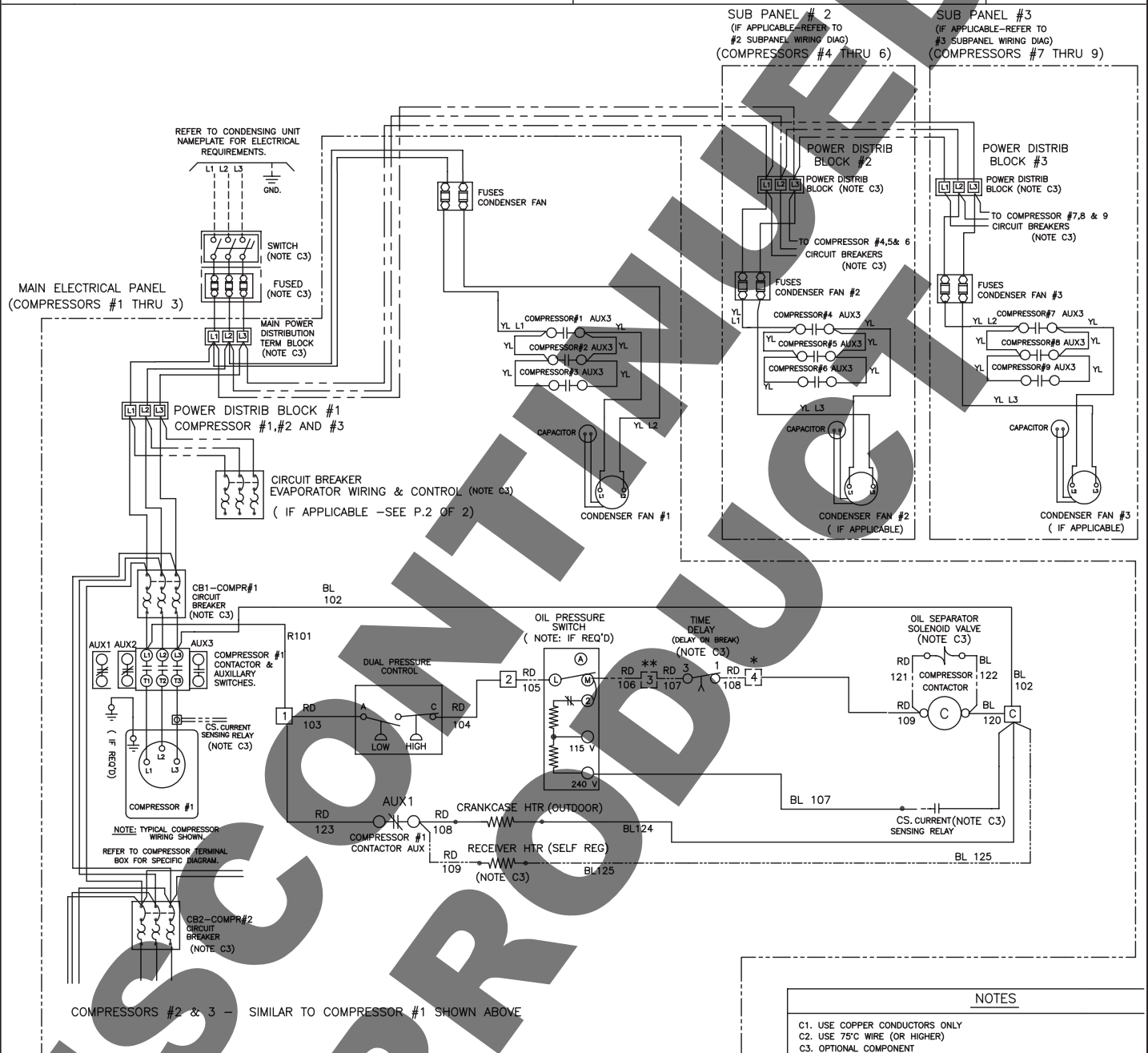

COMPRESSORS #2 & 3 - SIMILAR TO COMPRESSOR #1 SHOWN ABOVE

NOTES

- C1. USE COPPER CONDUCTORS ONLY
- C2. USE 75°C WIRE (OR HIGHER)
- C3. OPTIONAL COMPONENT
- C4. ALL FUSES TO BE CLASS CC OR J AND VOLTAGE RATED EQUAL (OR HIGHER) THAN OPERATING VOLTAGE

CONDUCTORS/WIRING

- FACTORY WIRING
- OPTIONAL WIRING
- WIRING BY OTHERS

ALL FIELD WIRING MUST BE DONE IN COMPLIANCE WITH ALL APPLICABLE LOCAL AND NATIONAL CODES.

REVISIONS		DIAGRAM NUMBER	
DATE	LTR	T3A1A-	P.1 OF 2
JAN23/05	A		

WIRING DIAGRAM

MAIN PANEL TYPICAL COND UNIT WIRING DIAGRAM
MAIN CONTROL PANEL - TYPICAL EVAPORATOR WIRING

AIR & ELECTRIC DEFFROST

P.2 OF 2

(ALSO REFER TO P.1OF 2)

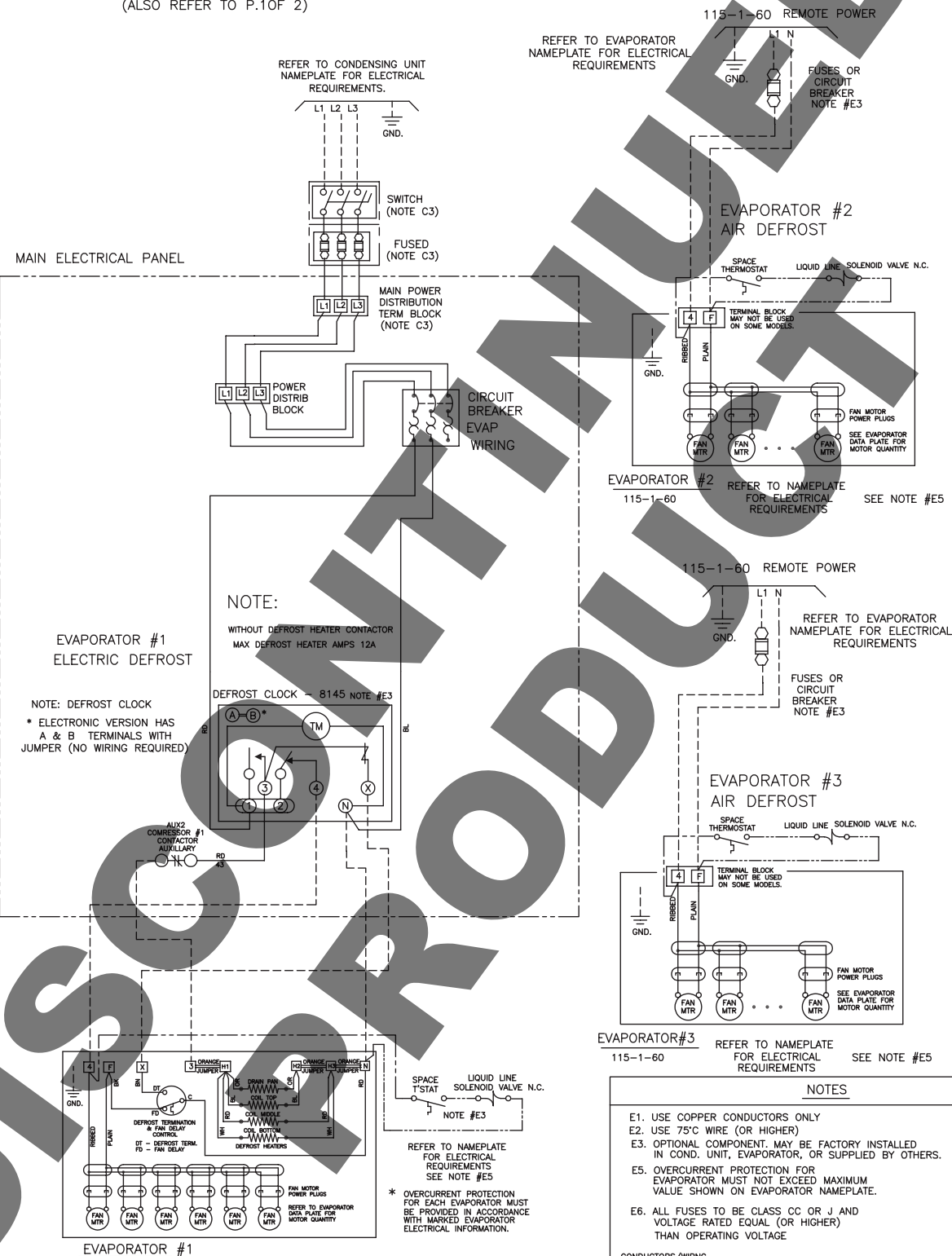

NOTES

- E1. USE COPPER CONDUCTORS ONLY
- E2. USE 75°C WIRE (OR HIGHER)
- E3. OPTIONAL COMPONENT; MAY BE FACTORY INSTALLED IN COND. UNIT, EVAPORATOR, OR SUPPLIED BY OTHERS.
- E5. OVERCURRENT PROTECTION FOR EVAPORATOR MUST NOT EXCEED MAXIMUM VALUE SHOWN ON EVAPORATOR NAMEPLATE.
- E6. ALL FUSES TO BE CLASS CC OR J AND VOLTAGE RATED EQUAL (OR HIGHER) THAN OPERATING VOLTAGE

CONDUCTORS/WIRING

- FACTORY WIRING
- - - OPTIONAL WIRING
- · · WIRING BY OTHERS

ALL FIELD WIRING MUST BE DONE IN COMPLIANCE WITH ALL APPLICABLE LOCAL AND NATIONAL CODES.

REVISIONS	DIAGRAM NUMBER
DATE	LTR
JAN23/05	A

T3A1A- P.2 OF 2

NOTES:

**DISCONTINUED
PRODUCT**

System	
Model Number	Date of Start-Up
Serial Number	Service Contractor
Refrigerant	Phone
Electrical Supply	Fax

DISCONTINUED PRODUCT



NATIONAL REFRIGERATION & AIR CONDITIONING CANADA CORP.

159 Roy Blvd. • Brantford • Ontario, Canada N3R 7K1

PHONE: (519) 751-0444 • 800-463-9517 • FAX (519) 753-1140



Due to National Refrigeration's policy of continuous product improvement, we reserve the right to make changes without notice.