



National Refrigeration and
Air Conditioning Canada Corp.
159 Roy Blvd., P.O. Box 2020,
Brantford, ON, Canada
N3T 5Y6

APPLICATION BULLETIN
TPB-4006-02-1
CS-322
Rev. 1 August 2023

TQ-QUIETLINE – XC35CX (RTC) REAL TIME CLOCK

New XC35CX control

Beginning August 2023, Trenton will begin to manufacture all models in the Quiet Line Condensing unit product line with an updated XC35CX Dixell control. The updated control includes the functionality of a programmable (RTC) Real Time Clock. The RTC eliminates the need for a conventional mechanical time clock for air and electric defrost applications. This bulletin serves to highlight the wiring and programming changes required to activate the RTC feature on Non ESP+ applications.

Part#1111400 Firmware: V6-MT or V6-LT

Medium/High-Temperature Units (Timed Air Defrost)

Medium and High-Temperature units are now equipped with a control relay “R1 Defrost Timer Relay”. This relay requires field wiring to the common terminal on the room thermostat. This will de-energize the liquid line solenoid coil, close the solenoid valve, and pump down the system to perform the air defrost cycle.

Figure:1 Wiring Diagram: S2Q1W6/KA151XC

Low-Temperature Units (Timed Electric Defrost)

Low-temperature units are now equipped with a control relay “R1 Defrost Timer Relay”. This relay requires field wiring to the common terminal on the room thermostat and the evaporator fan motors or fan contactor coil, depending on the evaporator(s) used. This will de-energize the fans and liquid line solenoid coil, close the solenoid valve, and pump down the system to perform the electric defrost cycle. An additional control relay “R2 Defrost Termination Relay” requires wiring to the “X” terminal on the evaporator terminal board. When energized, the relay coil will close a set of normally open (N.O) contacts wired to terminals 22 & 23 on the XC35CX control and terminate defrost.

Figure 2:Wiring Diagram: T3Q1W6/LPE152-XC

XC35CX Control Programming

All Quiet line Condensing units with the updated XC35CX control will not have timed defrost capabilities enabled. All defrost settings will remain dormant unless specifically enabled. To enable the RTC functionality the following will need to be manually entered. “Hur” Setting for local time and Date, “Pdt” Pump down duration time. Time allowed for pump down when a defrost cycle is initiated, default Time (2 minutes), “otd” Off Time Defrost Duration Default (40 Minutes).

Defrost Cycle Start time “df1-8” and “nu” Setpoints will need to be programmed to enable the Defrost clock functionality (Up to 8 Defrost Cycles available).

Figure:3 Real Time Clock and Defrost Functions (Programming Menu)



National Refrigeration and
Air Conditioning Canada Corp.
159 Roy Blvd., P.O. Box 2020,
Brantford, ON, Canada
N3T 5Y6

APPLICATION BULLETIN
TPB-4006-02-1
CS-322
Rev. 1 August 2023

Fig:1 Wiring Diagram: S2Q1W6/KA151XC

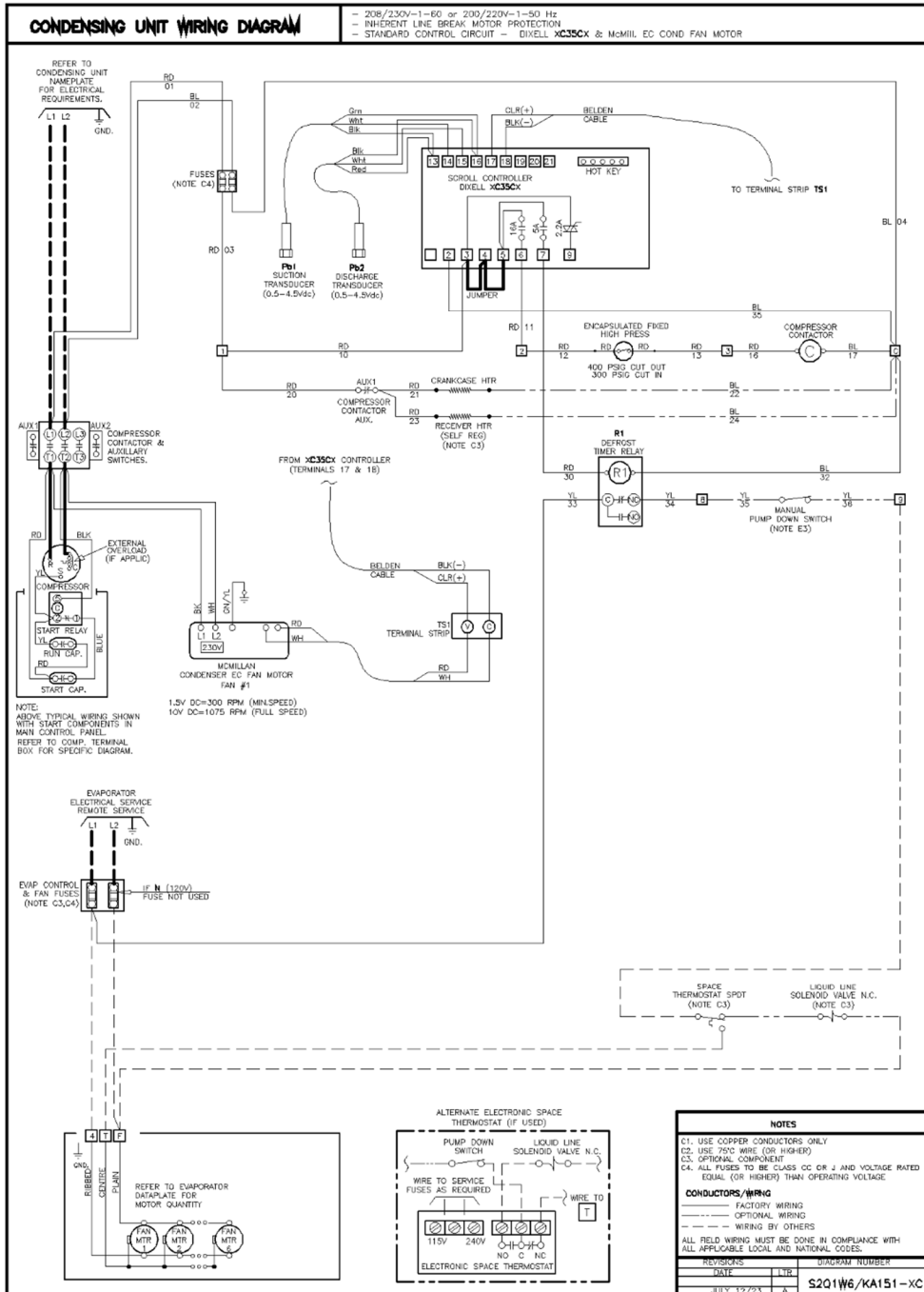



National Refrigeration and
Air Conditioning Canada Corp.
159 Roy Blvd., P.O. Box 2020,
Brantford, ON, Canada
N3T 5Y6

APPLICATION BULLETIN
TPB-4006-02-1
CS-322
Rev. 1 August 2023

Fig 2:Wiring Diagram: T3Q1W6/LPE152-X

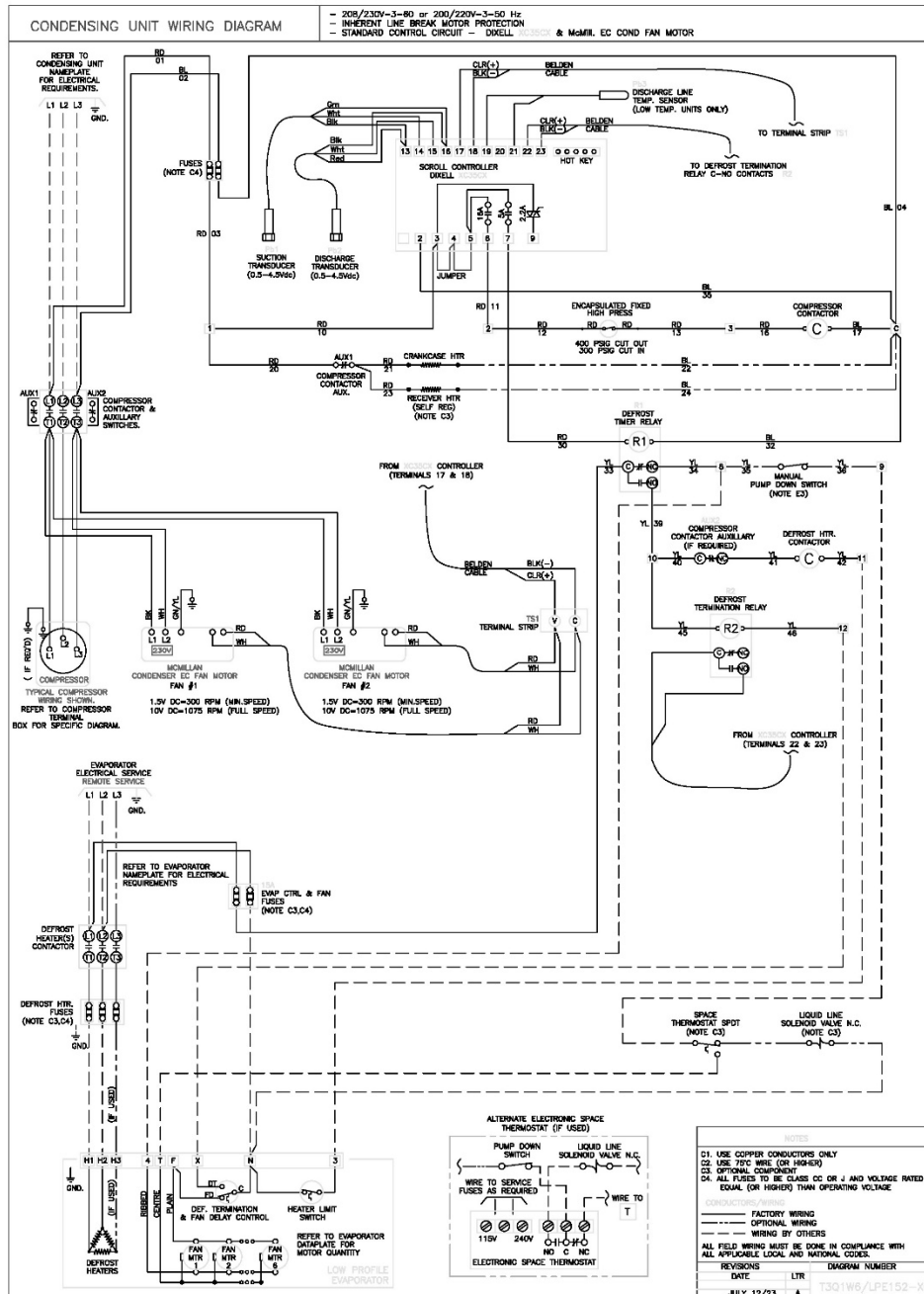



Fig:3 Real Time Clock and Defrost Functions (Programming Menu)

REAL TIME CLOCK AND DEFROST FUNCTIONS (Controlling parameters: Configuration Setpoint, alarms and defrost schedule)

Parameter	Description	Low	Medium	Prog. Level
Std	Set point for Pump-down	7	27	Pr2
HYd	Hysteresis for Pump-down	14	20	Pr2
Pdt	Pump down duration	2		Pr1
otd	Off time defrost duration	40		Pr1
oA2	Digital output AUX2 configuration (Relay 5A)	PdU		Pr2
i2F	Digital input 2 function	PdE		Pr2
i2P	Digital input 2 polarity	CL		Pr2
dF1	1st Defrost Cycle starting time	nu		Pr1
dF2	2nd Defrost Cycle starting time	nu		Pr1
dF3	3rd Defrost Cycle starting time	nu		Pr1
dF4	4th Defrost Cycle starting time	nu		Pr1
dF5	5th Defrost Cycle starting time	nu		Pr1
dF6	6th Defrost Cycle starting time	nu		Pr1
dF7	7th Defrost Cycle starting time	nu		Pr1
dF8	8th Defrost Cycle starting time	nu		Pr1

Refer to <https://docs.k-rp.com/1110230.pdf> for additional Programming instructions.

1. Additional Resources

Trenton Refrigeration website: [TQZ - Outdoor Air Cooled Quiet Scroll Condensing Units - Trenton Refrigeration \(t-rp.com\)](https://www.trentonref.com)

United Refrigeration website: <http://www.uri.com>