



Product Data & Installation

Bulletin T50-TGL-PDI-1

Part # 1112197

TGL Gas Coolers

One to Twelve Fan Motors

CO²

Electrical Power:

208-230/3/60, 460/3/60, 575/3/60

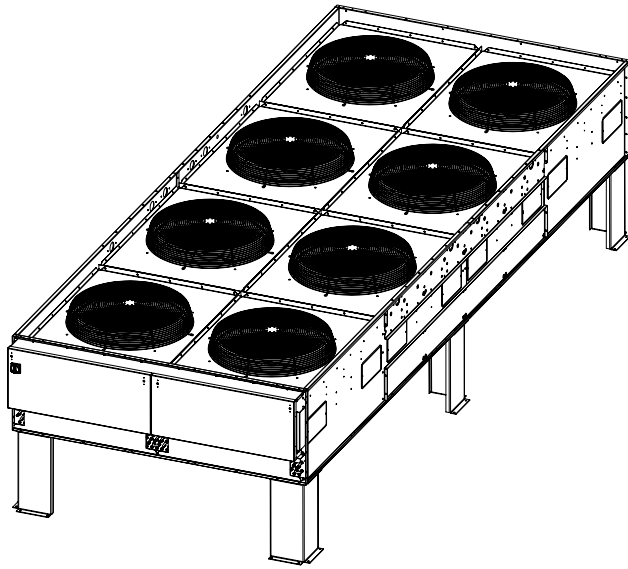

**60
Hz**

CONTENTS	Page
Nomenclature	2
Features & Options.....	2
General Specifications.....	3
Electrical Data	4
EC Motor Application	5
Wiring Diagram.....	6
Dimensional Data	7 - 10
Installation	11 - 13
Cloudburst Pre-Cooling System	14
Gas Cooler Selection.....	15
Project Information	18
Product Support Resources	19
“As Built” Service Parts List.....	BACK

NOMENCLATURE

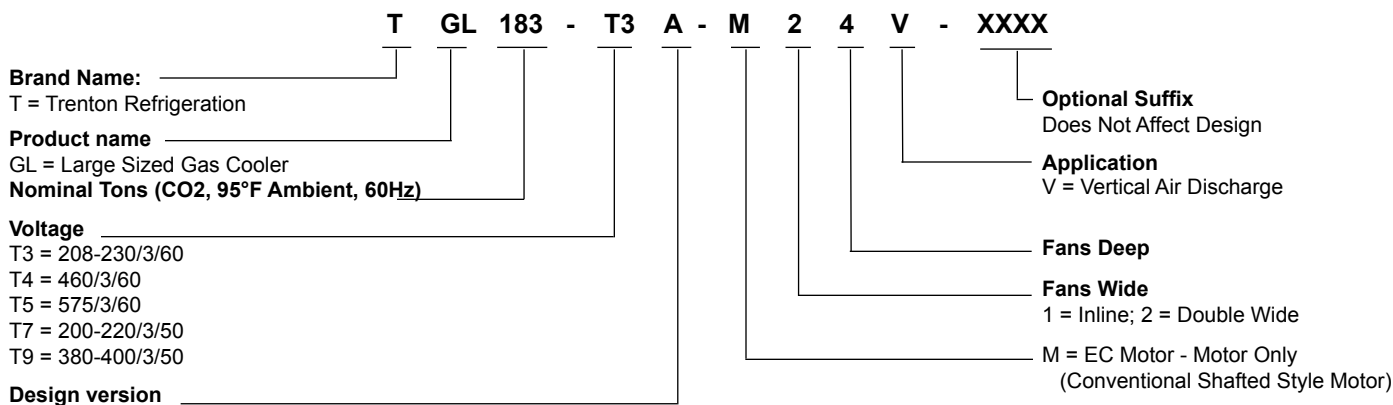

Standard Features Include

- 120 Bar Certification
- Narrow width design to suit shipment in containers.
- THERMOSPAN™ coil design feature eliminates tube failure on tube sheets.
- 3/8 O.D Heavy Wall Copper Tube and aluminum fins on all models
- Variable Speed EC Motors with male electrical plug moisture slinger and rainshield for complete weather protection
- Rugged heavy-gauge galvanized steel rail motor mounts/support.
- 316 Stainless Steel Headers
- All fan sections are individually baffled with full height partitions and clean-out panels.
- Heavy-gauge galvanized steel cabinet construction assembled with zinc plated huck bolts supported on heavy-duty legs.
- 36" or 48" legs shipped loose (varies with model)
- 2-Fan wide units have two equal circuits
- Terminal block
- Single entering electrical service
- Control circuit voltage – 230 V
- Control circuit transformer where applicable

Options Available

- Individual fan motor fusing
- Non-fused disconnect
- Horizontal air discharge configuration
- 48" Extended leg kit with cross bracing available on 36" leg models
- Optional fin materials
- Optional coil coating
- Voltages available for 60Hz or 50Hz
- Steel to copper transition couplings for field piping connections
- Adiabatic pre-cooling system (shipped loose or factory installed)

MODEL KGL	FPI	FANS	NO. OF FEEDS	ECM			CAPACITY (2)	PIPING CONNECTIONS (INLET AND OUTLET)		208-230V/460V APPROX. DRY SHIPPING WEIGHTS		575V APPROX. DRY SHIPPING WEIGHTS	
				AIR FLOW RATES		SOUND LEVEL		STAINLESS STEEL (ID)		LBS	KGS	LBS	KGS
				CFM	m3/h	dB(A)	(TONS)	INCHES	mm				

SINGLE ROW MODELS

013	8	1 x 1	7	11000	18690	66	12.8	1.0	25	532	242	691	314
014	10	1 x 1	7	10700	18180	66	14.5	1.0	25	546	248	705	321
016	12	1 x 1	7	10300	17500	66	15.8	1.0	25	560	255	719	327
024	8	1 x 2	11	22000	37380	68	24.3	1.0	25	1078	490	1281	582
028	10	1 x 2	11	21300	36190	68	27.6	1.0	25	1092	496	1295	589
030	12	1 x 2	11	20600	35000	68	30.2	1.0	25	1120	509	1323	601
037	8	1 x 3	14	33100	56240	69	37.4	1.5	38	1610	732	1956	889
042	10	1 x 3	14	32000	54370	69	42.3	1.5	38	1645	748	1991	905
046	12	1 x 3	14	30900	52500	69	46.3	1.5	38	1680	764	2026	921
048	8	1 x 4	28	44000	74760	70	47.7	1.5	38	2135	970	2596	1180
054	10	1 x 4	28	42700	72550	70	54.1	1.5	38	2170	986	2631	1196
059	12	1 x 4	28	41200	70000	70	59.3	1.5	38	2240	1018	2701	1228
060	8	1 x 5	28	55000	93450	71	60.5	1.5	38	2695	1225	3228	1467
069	10	1 x 5	28	53400	90730	71	68.8	1.5	38	2730	1241	3263	1483
075	12	1 x 5	28	51500	87500	71	75.3	1.5	38	2800	1273	3333	1515
073	8	1 x 6	28	66000	112130	72	73.4	1.5	38	3185	1448	3893	1769
083	10	1 x 6	28	64100	108910	72	83.4	1.5	38	3220	1464	3928	1785
091	12	1 x 6	28	61800	105000	72	91.1	1.5	38	3290	1495	3998	1817

DOUBLE ROW MODELS

049	8	2 x 2	2 x 11	44100	74930	70	48.8	1.0	25	1813	824	2241	1018
055	10	2 x 2	2 x 11	42600	72380	70	55.3	1.0	25	1844	838	2272	1033
061	12	2 x 2	2 x 11	41200	70000	70	60.5	1.0	25	1906	866	2334	1061
074	8	2 x 3	2 x 14	66100	112300	72	74.7	1.5	38	2719	1236	3347	1521
085	10	2 x 3	2 x 14	64000	108740	72	84.6	1.5	38	2781	1264	3409	1550
093	12	2 x 3	2 x 14	61800	105000	72	92.6	1.5	38	2844	1293	3472	1578
095	8	2 x 4	2 x 28	88000	149510	73	95.3	1.5	38	3625	1648	4341	1973
108	10	2 x 4	2 x 28	85400	145090	73	108.3	1.5	38	3688	1676	4404	2002
119	12	2 x 4	2 x 28	82400	140000	73	118.6	1.5	38	3781	1719	4498	2044
121	8	2 x 5	2 x 28	110000	186890	74	121.0	1.5	38	4563	2074	5372	2442
138	10	2 x 5	2 x 28	106800	181450	74	137.5	1.5	38	4625	2102	5434	2470
151	12	2 x 5	2 x 28	103000	175000	74	150.6	1.5	38	4719	2145	5528	2513
147	8	2 x 6	2 x 28	132000	224270	75	146.7	1.5	38	5438	2472	6598	2999
167	10	2 x 6	2 x 28	128200	217810	75	167.0	1.5	38	5500	2500	6661	3028
183	12	2 x 6	2 x 28	123600	210000	75	182.6	1.5	38	5625	2557	6786	3084

1 - SOUND PRESSURE LEVEL AT 30 FT.

2 - 95°F AMBIENT, 99°F GAS OUTLET, 240°F, 1358 PSI GAS INLET. FOR ALL OTHER CONDITIONS, CALL FACTORY FOR SELECTION.

208-230/3/60

NO. OF FAN MOTORS	TOTAL FLA	MCA	MOP	WATTS
1	6.2	7.8	15	1750
2	12.4	16.0	20	3500
3	18.6	20.2	25	5250
4	24.8	31.0	35	7000
5	31.0	36.0	40	8750
6	37.2	46.0	50	10500
8	49.6	61.0	70	14000
10	62.0	71.0	80	17500
12	74.4	91.0	100	21000

460/3/60

NO. OF FAN MOTORS	TOTAL FLA	MCA	MOP	WATTS
1	3.1	3.9	15	1750
2	6.2	7.0	15	3500
3	9.3	10.1	15	5250
4	12.4	16.0	20	7000
5	15.5	16.3	20	8750
6	18.6	21.0	25	10500
8	24.8	31.0	35	14000
10	31.0	36.0	40	17500
12	37.2	46.0	50	21000

575/3/60

NO. OF FAN MOTORS	TOTAL FLA	MCA	MOP	WATTS
1	2.6	3.3	15	1750
2	5.2	5.9	15	3500
3	7.8	8.5	15	5250
4	10.4	11.1	15	7000
5	13.0	16.0	20	8750
6	15.6	16.3	20	10500
8	20.8	26.0	30	14000
10	26.0	31.0	35	17500
12	31.2	36.0	40	21000

M.C.A. = Minimum Circuit Ampacity M.O.P. = Maximum Overcurrent Protection

Motors With Built-in Variable Speed –

Ideally the motors on the gas cooler should all be EC and simultaneously slow down/speed up together. This provides for maximum energy savings. However some applications may exist where just the last fan or pair of fans (ones closest to header) are solely EC motors. (The remaining conventional type motors are then cycled off by fan cycling pressure controls).

**Important Warnings:**

(Please read before handling motors)

1. When connecting the unit to the power supply, dangerous voltages occur. Due to motor capacitor discharge time, do not open the motor within 5 minutes after disconnection of all phases.
2. With a Control voltage fed in or a set speed value being saved, the motor will restart automatically after a power failure.
3. Dangerous external voltages can be present at the motor terminals even when the unit is turned off.
4. The Electronics housing can get hot.
5. The cycling on and off of EC motors should be controlled by the DC control voltage (i.e. 10V DC will turn motor off). Excessive cycling of the motor by line voltage contactors may cause stress on the motors and reduce the motor life.

Speed Adjustment Characteristics

The EC motor varies its speed linearly based on a 10-0V input signal. At 0 VDC, the motor runs at full speed. At 10 VDC, the motor turns off. A chart of the speed control curve is shown below. The motor can be controlled at any speed below its nominal RPM.

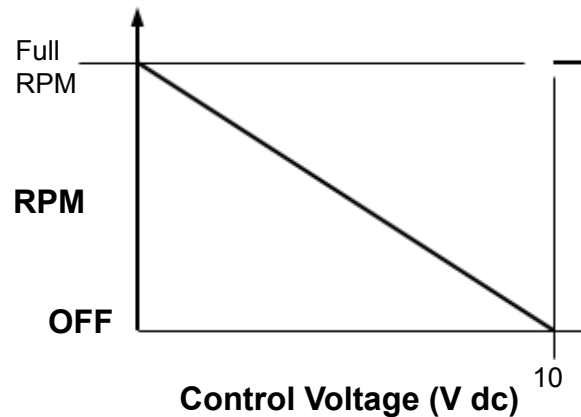
**Control Signal**

The input control signal can be supplied by an external control signal or from a factory installed proportional pressure control. Units with factory installed proportional pressure controls require no installation wiring and are adjusted with initial factory settings. These may require further adjustments to suit local field conditions.

External Control Signal (Supplied by others)

Contact control manufacturer for setup of external controller to provide a 10-0 VDC control signal. Wire the control signal to terminal board in unit control box. Refer to the EC wiring diagram for typical external signal control wiring.

208-230V / 460V SINGLE & DOUBLE ROW MODELS

SIDE VIEWS

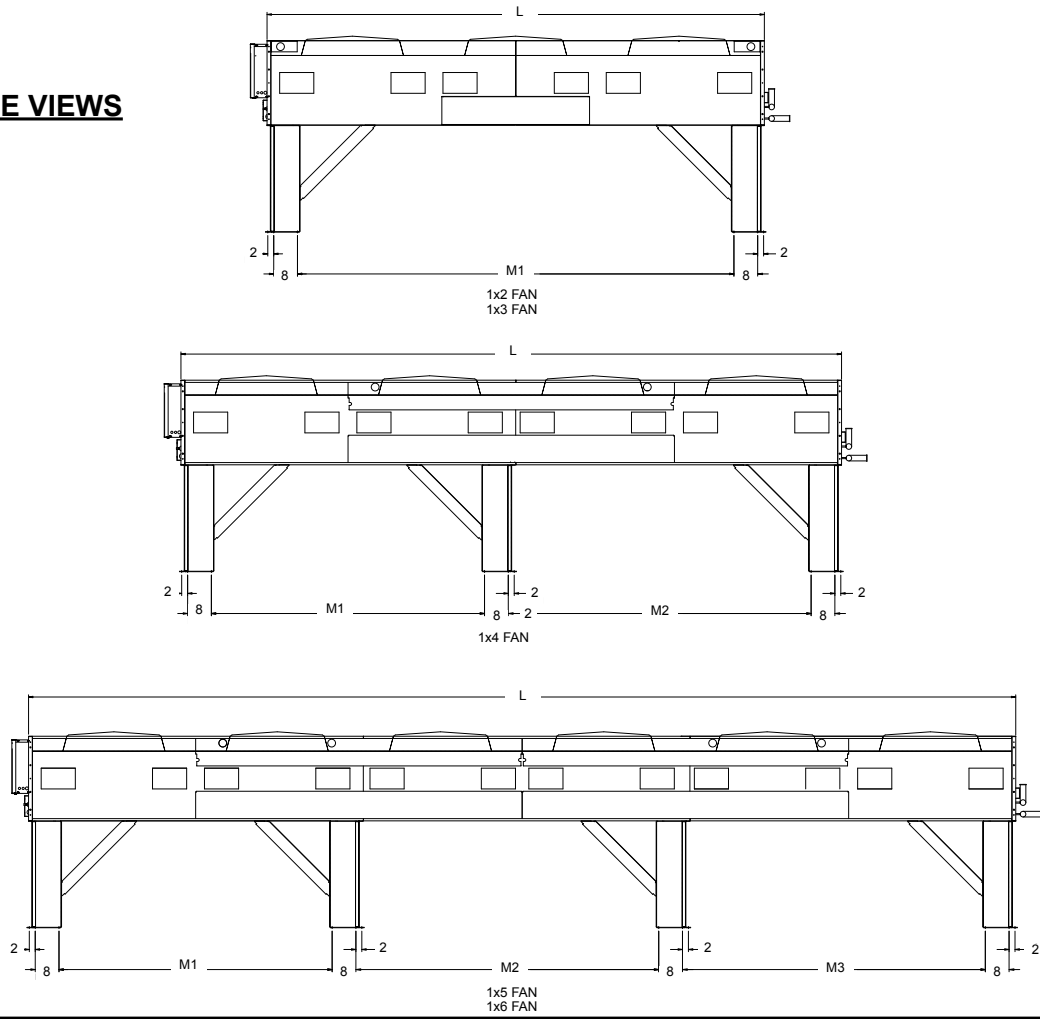

SINGLE ROW MODELS

DOUBLE ROW MODELS

ELECTRICAL END VIEW

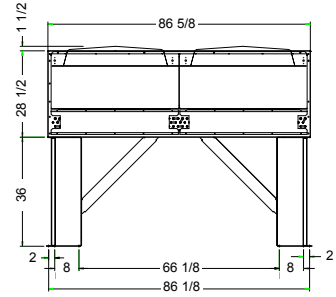
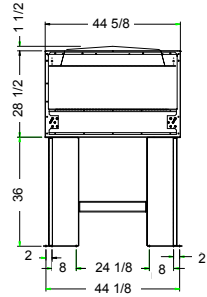

PIPING END VIEW

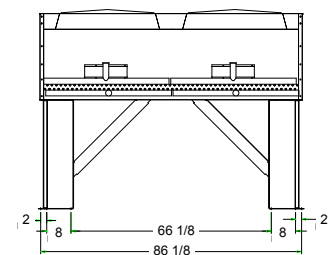
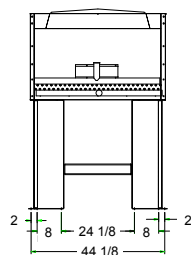

575V - SINGLE ROW MODELS

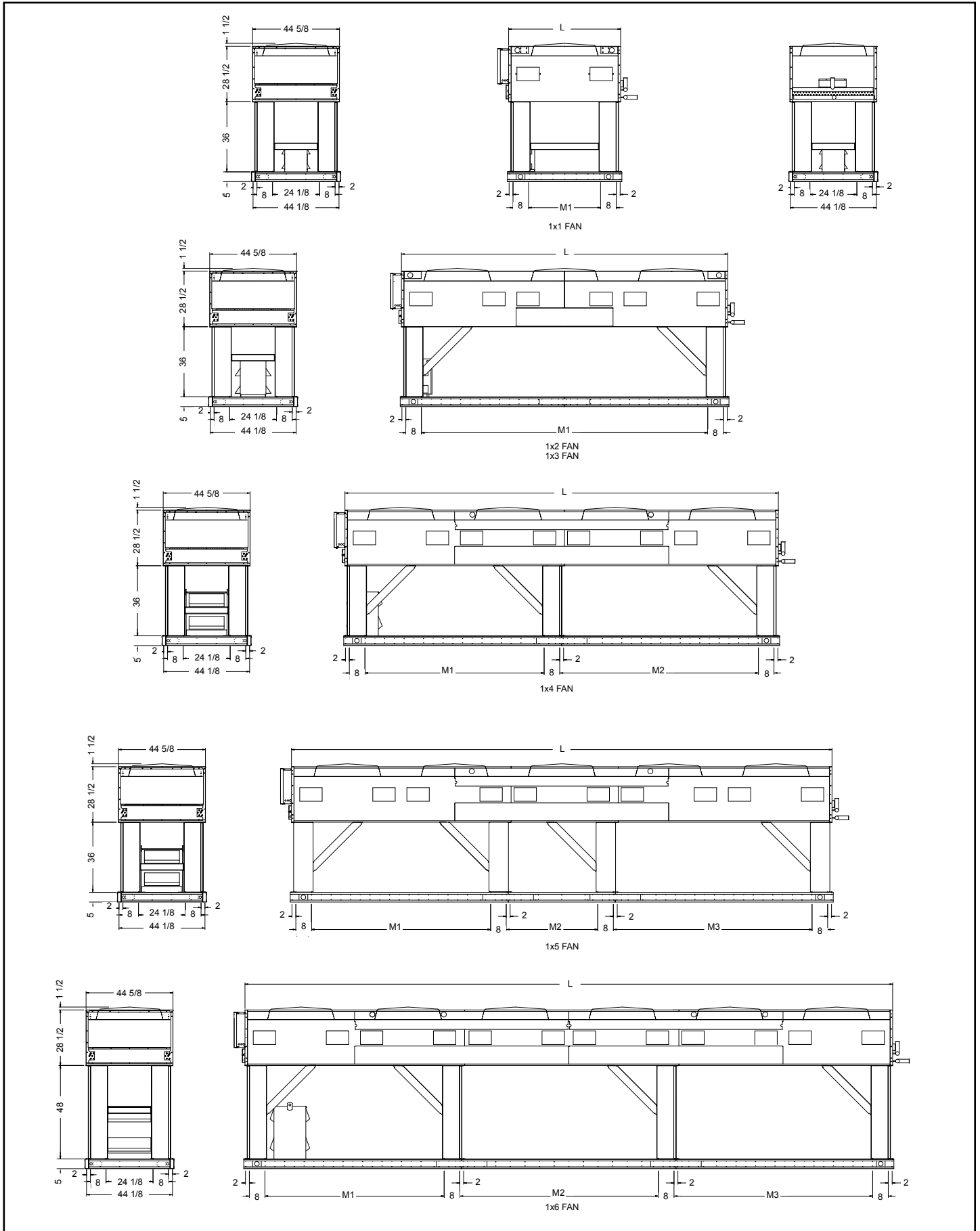

575V - DOUBLE ROW MODELS

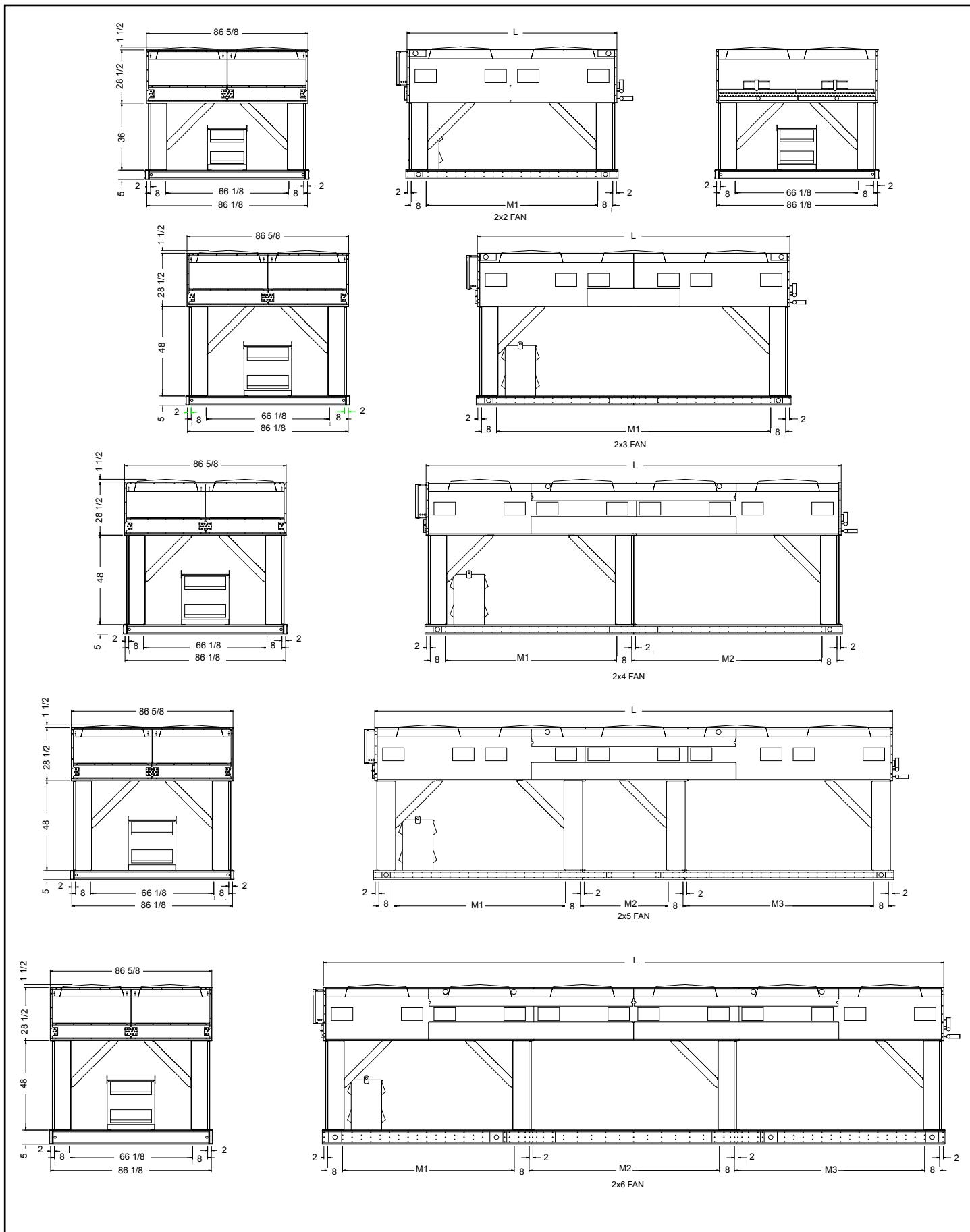

SINGLE ROW MODELS

MODEL GL	FANS LONG	L		M1		M2		M3	
		In.	mm	In.	mm	In.	mm	In.	mm
013	1	57.5	1460	37	939	-	-	-	-
014									
016									
024	2	112.5	2857	92	2336	-	-	-	-
028									
030									
037	3	167.5	4254	147	3733	-	-	-	-
042									
046									
048	4	222.5	5651	92	2336	102	2590	-	-
054									
059									
060	5	277.5	7048	92	2336	47	1193	102	2590
069									
075									
073	6	332.5	8445	92	2336	102	2590	102	2590
083									
091									

DOUBLE ROW MODELS

MODEL GL	FANS LONG	L		M1		M2		M3	
		In.	mm	In.	mm	In.	mm	In.	mm
049	2	112.5	2857	92	2336	-	-	-	-
055									
061									
074	3	167.5	4254	147	3733	-	-	-	-
085									
093									
095	4	222.5	5651	92	2336	102	2590	-	-
108									
119									
121	5	277.5	7048	92	2336	47	1193	102	2590
138									
151									
147	6	332.5	8445	92	2336	102	2590	102	2590
167									
183									

INSPECTION

A thorough inspection of the equipment, including all component parts and accessories, should be made immediately upon delivery. Any damage caused in transit, or missing parts, should be reported to the carrier at once. The consignee is responsible for making any claim for losses or damage. Electrical characteristics should also be checked at this time to ensure that they are correct.

LOCATION

Before handling and placing the unit into position a review of the most suitable location must be made. This gas cooler is designed for outdoor installation. A number of factors must be taken into consideration

when selecting a location. Most important is the provision for a supply of ambient air to the gas cooler, and removal of heated air from the immediate area. Higher condensing temperatures, decreased performance, and the possibility of equipment failure may result from inadequate air supply. Other considerations include:

1. Customer requests
2. Loading capacity of the roof or floor.
3. Distance to suitable electrical supply.
4. Accessibility for maintenance.
5. Local building codes.
6. Adjacent buildings relative to noise levels.

WALLS OR OBSTRUCTIONS

All sides of the unit must be a minimum of **4 feet (1.25 m)** away from any wall or obstruction. Overhead obstructions are not permitted. If enclosed by three walls, the gas cooler must be installed as indicated for units in a pit.

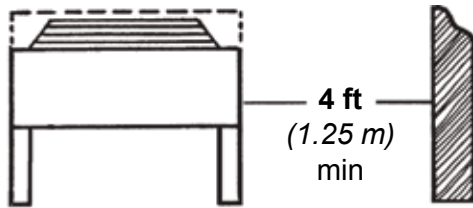

MULTIPLE UNITS

A minimum of **8 feet (2.5 m)** is required between multiple units placed side by side. If placed end to end, the minimum distance between units is **4 feet (1.25 m)**.

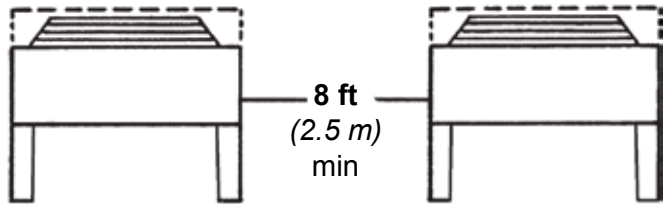

UNITS IN PITS

The top of the gas cooler must be level with, or above the top of the pit. In addition, a minimum of **8 feet (2.5 m)** is required between the unit and the pit walls.

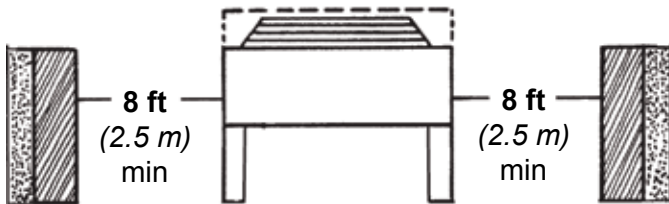

LOUVERS/FENCES

Louvers/fences must have a minimum of 80% free area and **4 feet (1.25 m)** minimum clearance between the unit and louvers/fence. Height of louver/fence must not exceed top of unit.

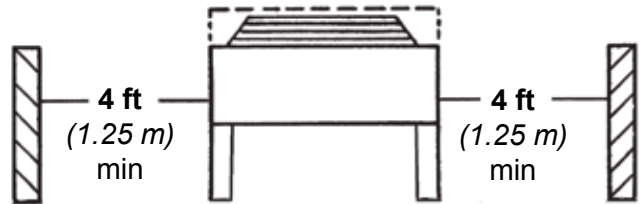

LIFTING INSTRUCTIONS

Air cooled gas coolers are large, heavy mechanical equipment and must be handled as such. A fully qualified and properly equipped crew with necessary rigging should be engaged to set the gas cooler into position. Lifting holes have been provided at the corners or along sides for attaching lifting slings. Spreader bars must be used when lifting so that lifting forces are applied vertically. See Fig. 2. **Under no circumstances should the coil headers or return bends be used in lifting or moving the gas cooler.**

FIG 1.

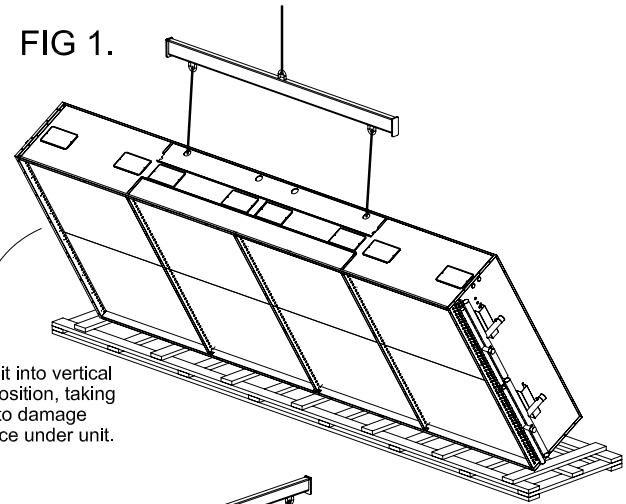

Lower unit into vertical air flow position, taking care not to damage coil surface under unit.

FIG 2.

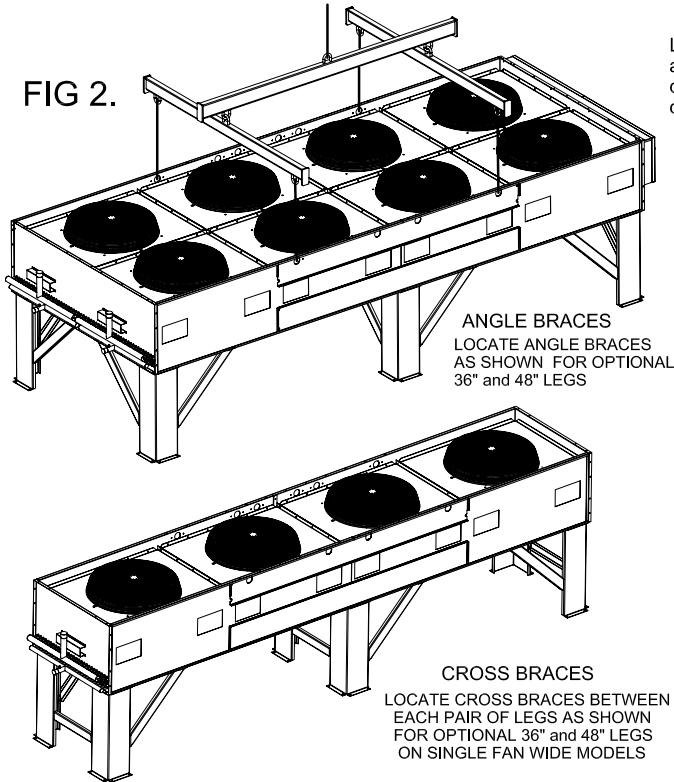

ANGLE BRACES
LOCATE ANGLE BRACES AS SHOWN FOR OPTIONAL 36" and 48" LEGS

CROSS BRACES
LOCATE CROSS BRACES BETWEEN EACH PAIR OF LEGS AS SHOWN FOR OPTIONAL 36" and 48" LEGS ON SINGLE FAN WIDE MODELS

Note:

Units designed for horizontal air flow will be shipped with leg structure installed. Lifting lugs are provided on unit base rails. Ensure that unit top side is stabilized to prevent tipping while lifting unit into place.

Ensure the unit is placed in a level position (to ensure proper drainage of liquid refrigerant and oil). The legs should be securely anchored to the building structure, sleeper or concrete pad. The weight of the gas cooler alone is not enough to hold in place during a strong wind, the legs must be anchored.

LEG INSTALLATION INSTRUCTIONS

FIG 3.

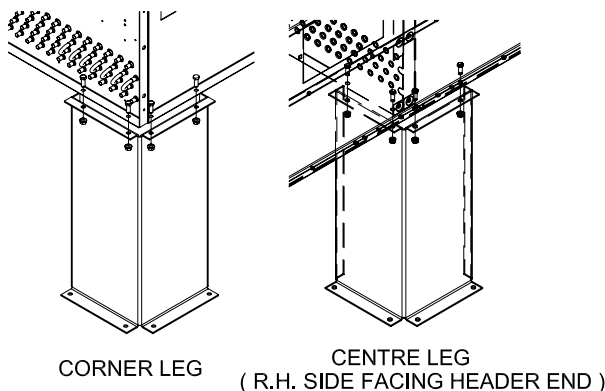

CORNER LEG

CENTRE LEG
(R.H. SIDE FACING HEADER END)

1) Assemble centre leg as shown. Remove two bolts from bottom flange of unit side panels that match the hole pattern on the top flanges of both legs. Attach center legs using hardware provided at center divider panel location. Replace bolts that were removed from from side panels to secure leg assembly to bottom flanges of unit side panels.

2) Assemble four corner legs to bottom flanges on unit side panels and end panels using hardware provided, at matching mounting hole patterns. All legs are the same.

ELECTRICAL WIRING

All wiring and connections to the air cooled gas cooler must be made in accordance with the National Electrical Code and all local codes and regulations. Any wiring diagrams shown are basic and do not necessarily include electrical components which must be field supplied. (see pages 18-20 for typical wiring diagrams).

Refer to the Electrical Specifications table on pages 5, 10 and 15) for voltage availability and entering service requirements.

SYSTEM START-UP CHECKS

1. Check the electrical characteristics of all components to be sure they agree with the power supply.
2. Check tightness of all fans and motor mounts.
3. Check tightness of all electrical connections.
4. Upon start-up, check fans for correct rotation. Air is drawn through the gas cooler coil. To change rotation on 3 phase units reverse any two (2) fan motor leads.
5. All system piping must be thoroughly leak checked before a refrigerant charge is introduced.

MAINTENANCE

The most effective way to prevent potential problems with this air cooled gas cooler is to have a **SEMI-ANNUAL INSPECTION** performed by a qualified refrigeration service mechanic.

1. **WHEN SERVICING EQUIPMENT, THE MAIN POWER SUPPLY MUST BE DISCONNECTED TO PREVENT POTENTIAL HAZARDOUS RISK.**
2. Check all electrical components for damage.
Tighten any loose connections.
3. Check settings of all controls to ensure proper operation.
4. Look for any wear on wires or refrigerant lines that may have been caused by excessive vibrations or rubbing on metal parts
5. Short cycling fan motors can result in premature failure of the fan blades and/or motors. Failing to correct this problem may, over time, cause the rivets on fan blades to become loose. If this happens, the fan blade may crack or tear, causing extreme vibration, potentially triggering the motor and mounts to fail.
6. Check the tightness of all fan blades and motors.
Remove any dirt or debris that could affect the balance of the fan blade.
7. Fan motors are permanently lubricated and require only visual inspection

CLOUDBURST – ADVANCED PRE-COOLING SYSTEM

The Cloudburst system provides a high-pressure automated mist that increases coil efficiency and capacity in high-temperature conditions by bringing the inlet dry bulb temperature closer to wet bulb. A thermostat controls a VFD that operates the pump up to a maximum of 1500 PSI.

The high-pressure mist lines are 316 stainless steel. The low-flow misting nozzles are self-cleaning with an anti-drip body. Included is a single 5-micron sediment filtration assembly that utilizes a reusable cartridge. The high-

pressure misting package comes in a powder-coated white case, and the control panel is IP55 rated. It is offered in 220V or 460V 60Hz 3 phase.

The pre-cooling misting package can be ordered as a shipped loose item for field installation, or as a factory installed and wired option.

cloudburst.com/pre-cooling

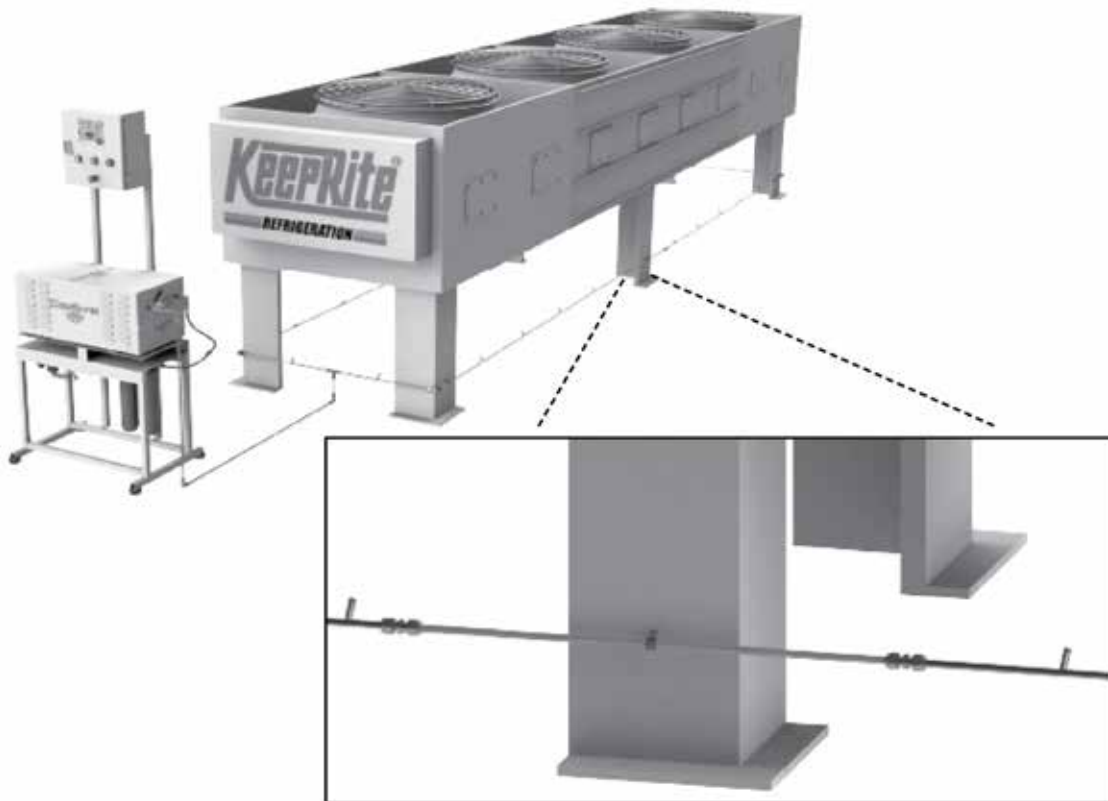

Gas Cooler Selection

All seven (7) items noted below are required, a selection will not be provided if any items are missing or unknown.

1. **Ambient Temperature**
2. **Gas Cooler Entering Temperature**
3. **Gas Cooler Inlet Pressure**
4. **Gas Outlet Temperature**
5. **Required Capacity**
6. **Fins per Inch**
7. **Voltage**

The following information must be fully completed and submitted via email to acc-fc@k-rp.com to obtain a gas cooler selection.

CO2 System Design Parameters

1. Ambient Temperature

2. Gas Cooler Entering Temperature

3. Gas Cooler Inlet Pressure

4. Gas Outlet Temperature

* Mass Flow (Optional)

5. Required Capacity

Gas Cooler Parameters

6. Fins per Inch

7. Voltage

* Mass flow is optional but may be used to validate the selection

NOTES

NOTES

System	
Model Number	Date of Start-Up
Serial Number	Service Contractor
Refrigerant	Phone
Electrical Supply	E-mail



PRODUCT SUPPORT

web: t-rp.com/tgl
email: acc-fc@t-rp.com
call: 1-844-893-3222 x526



TROUBLESHOOTING

email: troubleshooting@t-rp.com
call: 1-844-893-3222 x529



SERVICE PARTS

web: t-rp.com/parts
email: parts@t-rp.com
call: 1-844-893-3222 x504



WARRANTY

web: t-rp.com/warranty
email: warranty@t-rp.com
call: 1-844-893-3222 x507



ORDERS

email: orders@t-rp.com
call: 1-844-893-3222 x501



SHIPPING

email: shipping@t-rp.com
call: 1-844-893-3222 x503

Service Parts List Label To Be Attached HERE



Trenton Refrigeration
Brantford, ON • Longview, TX
1-800-463-9517 info@t-rp.com www.t-rp.com

